

# ***First Unit***

# COURSE OF THERMOFLUIDS I

- **Profesor:**

**Elkin G. Flórez S.**

**Profesor Titular**

Dr. En Ing. Mecánica, Fluidos y Aeronáutica de la Universidad Politécnica de Cataluña, Barcelona-España

M.Sc. En Ing. Química y de Procesos, Universidad Rovira i Virgili, Tarragona-España

M.Sc. En Ing. Mecánica, Universidad de los Andes, Bogotá-Colombia

Ing. Mecánico, Universidad Francisco de Paula Santander, Cúcuta-Colombia

- **Oficina y Horario de Atención:**

1er. Piso del Edificio Virgilio Barco (Fac. de Ingenierías y Arquitectura)

Martes de 8:00 AM a 12:00 M

[Contenido Programático:](#) [Página web del programa](#)

# COURSE OF THERMOFLUIDS I

## ARTÍCULO 32.- Aplicación de Evaluaciones:

a. Establézcase las semanas quinta (5), décima primera (11) y décima sexta (16), como fechas para realizar las evaluaciones de cada una de las asignaturas de un programa académico.

b. En las semanas que se realicen las evaluaciones parciales, no se desarrollarán clases de los cursos respectivos del programa académico.

PRIMER CORTE		SEGUNDO CORTE		TERCER CORTE	
35%		35%		30%	
20%	15%	20%	15%	20%	10%
Prueba escrita	Quices, trabajos, etc.	Prueba escrita	Quices, trabajos, etc.	Prueba escrita	Quices, trabajos, etc.

El Examen de Habilitación se presentará en la fecha y hora fijada por la Universidad, en un lapso no menor de cinco (5) días calendario, entre el examen final de un curso y su habilitación. La calificación obtenida en el Examen de Habilitación, reemplazará la nota definitiva de esta asignatura.

# INTRODUCTION TO THERMAL-FLUID SCIENCES

- **Thermal-fluid sciences:** The physical sciences that deal with energy and the transfer, transport, and conversion of energy.
- Thermal-fluid sciences are studied under the subcategories of
  - ✓ thermodynamics
  - ✓ heat transfer
  - ✓ fluid mechanics

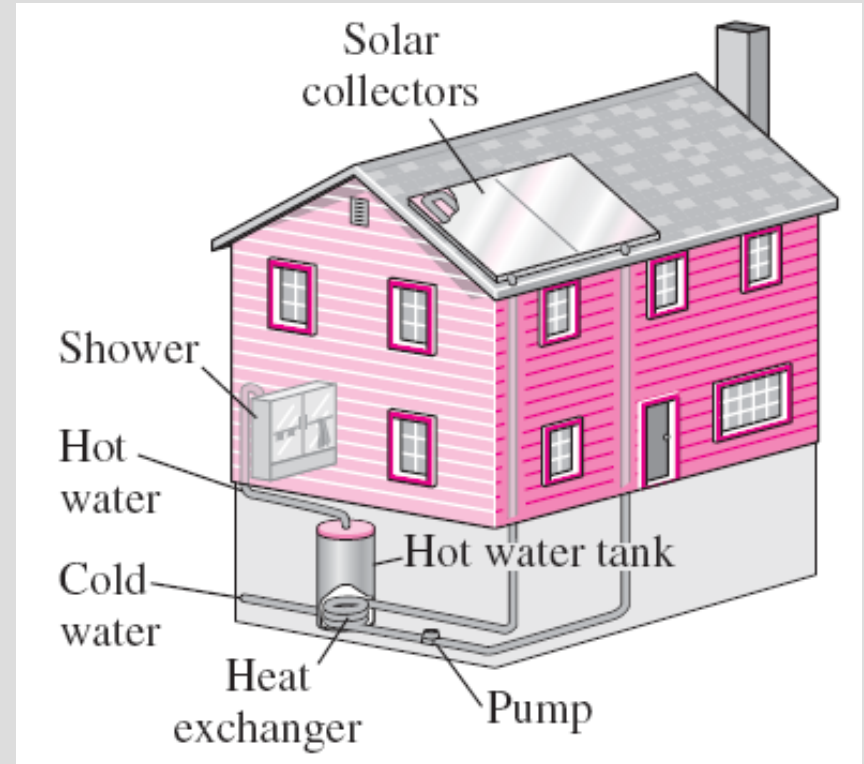

The design of many engineering systems, such as this solar hot water system, involves thermal-fluid sciences.

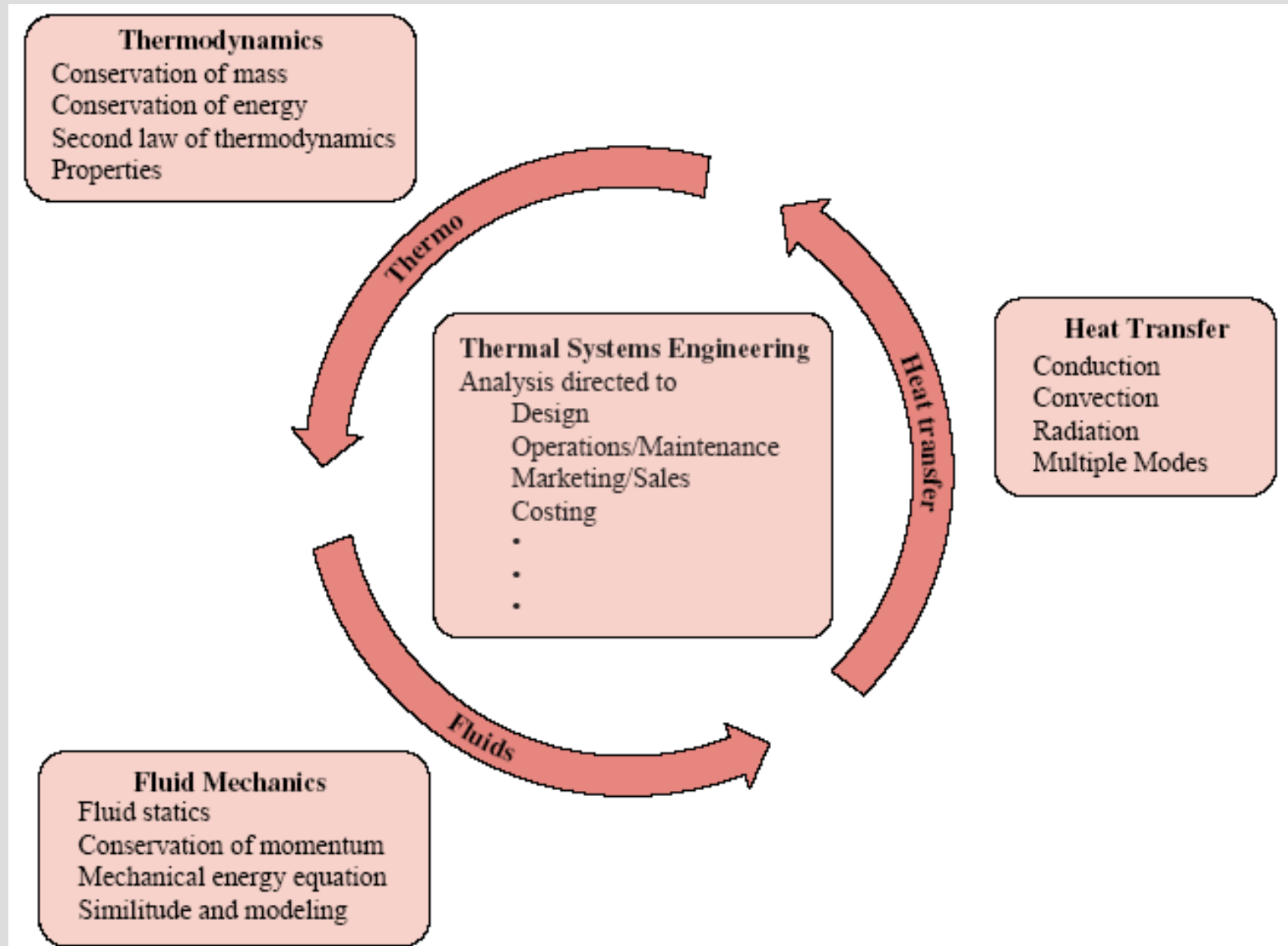

*Figure 1.5* The disciplines of thermodynamics, fluid mechanics, and heat transfer involve fundamentals and principles essential for the practice of thermal systems engineering.

# FIGURE 1-5

## Some application areas of thermodynamics.

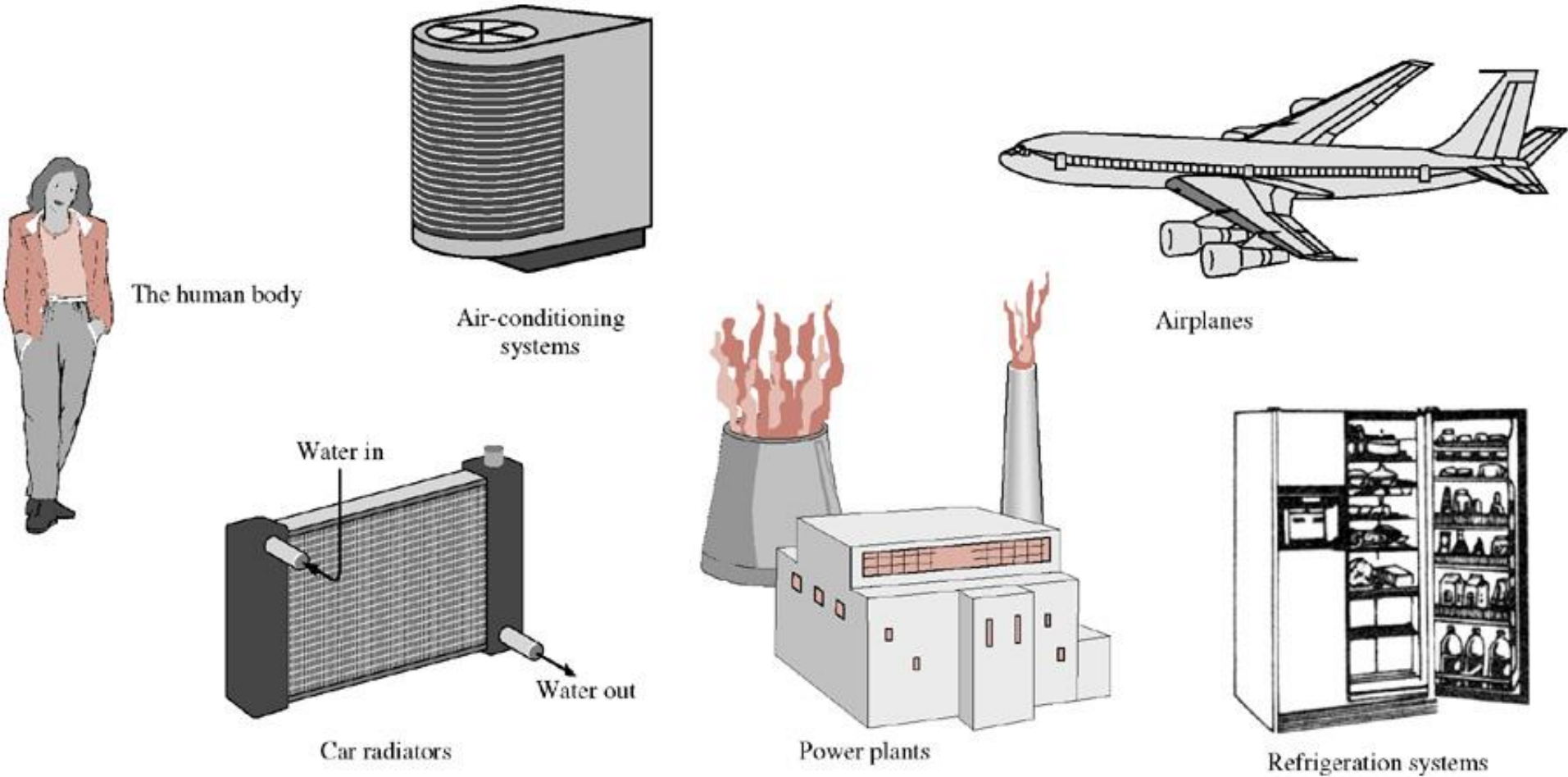

**FIGURE 1-5**  
Some application areas of  
thermodynamics.

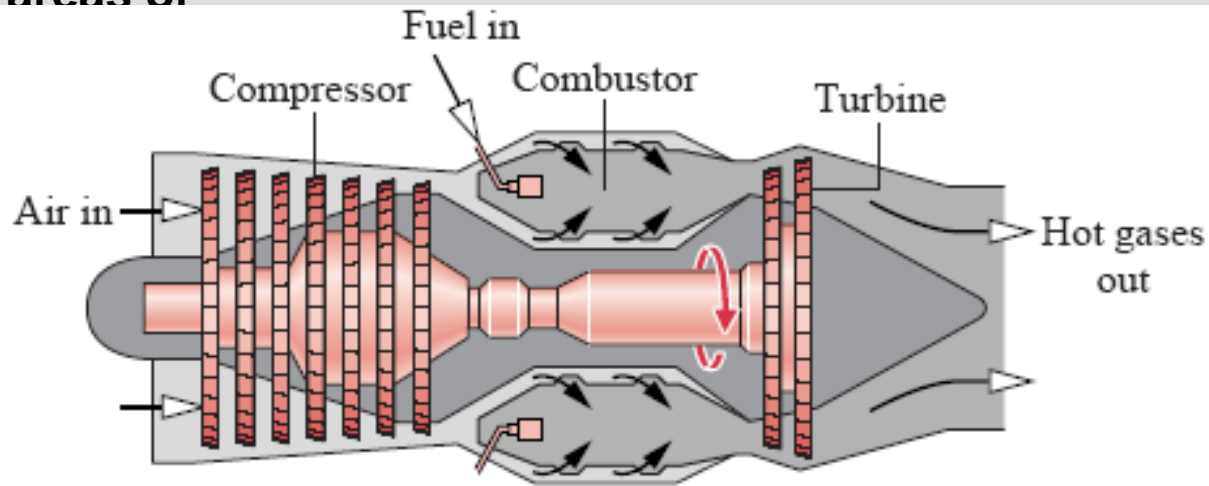

Turbojet engine

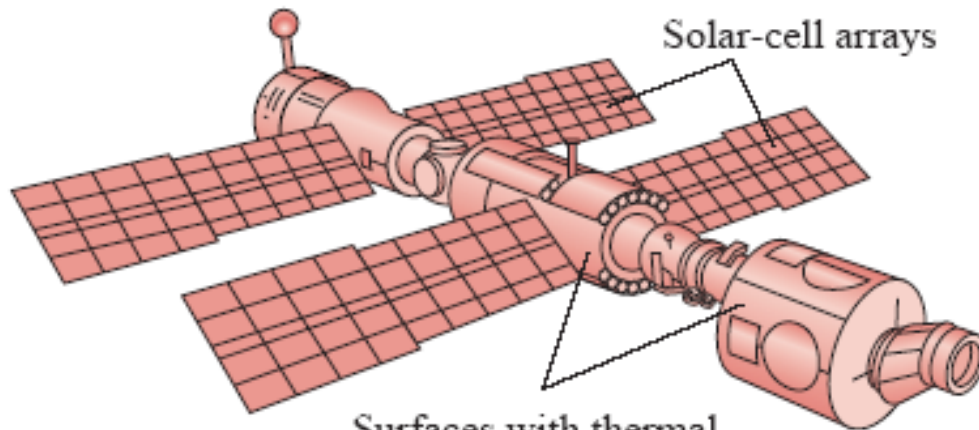

Surfaces with thermal  
control coatings  
International Space Station

# FIGURE 1-5

## Some application areas of thermodynamics.

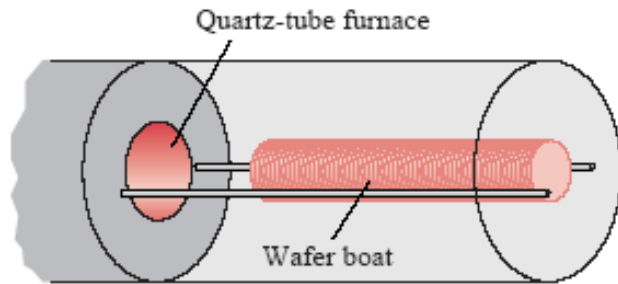

High-temperature annealing of silicon wafers

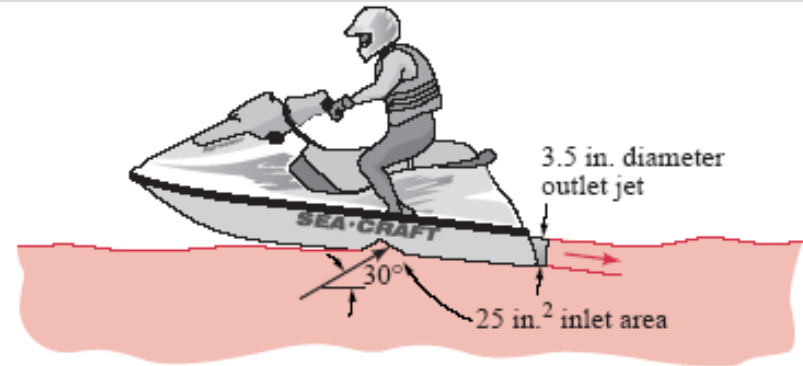

Jet ski water =-pump propulsion

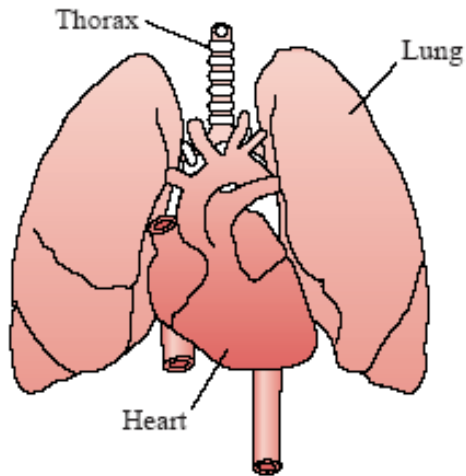

Human cardiovascular system

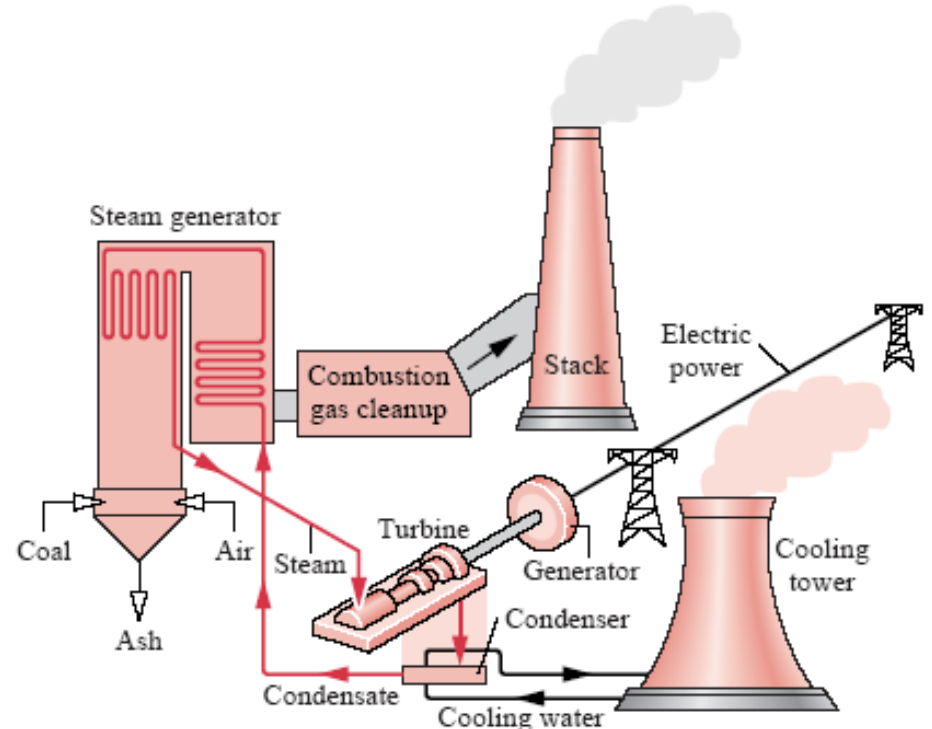



## FIGURE 1-5 Some application areas of thermodynamics.

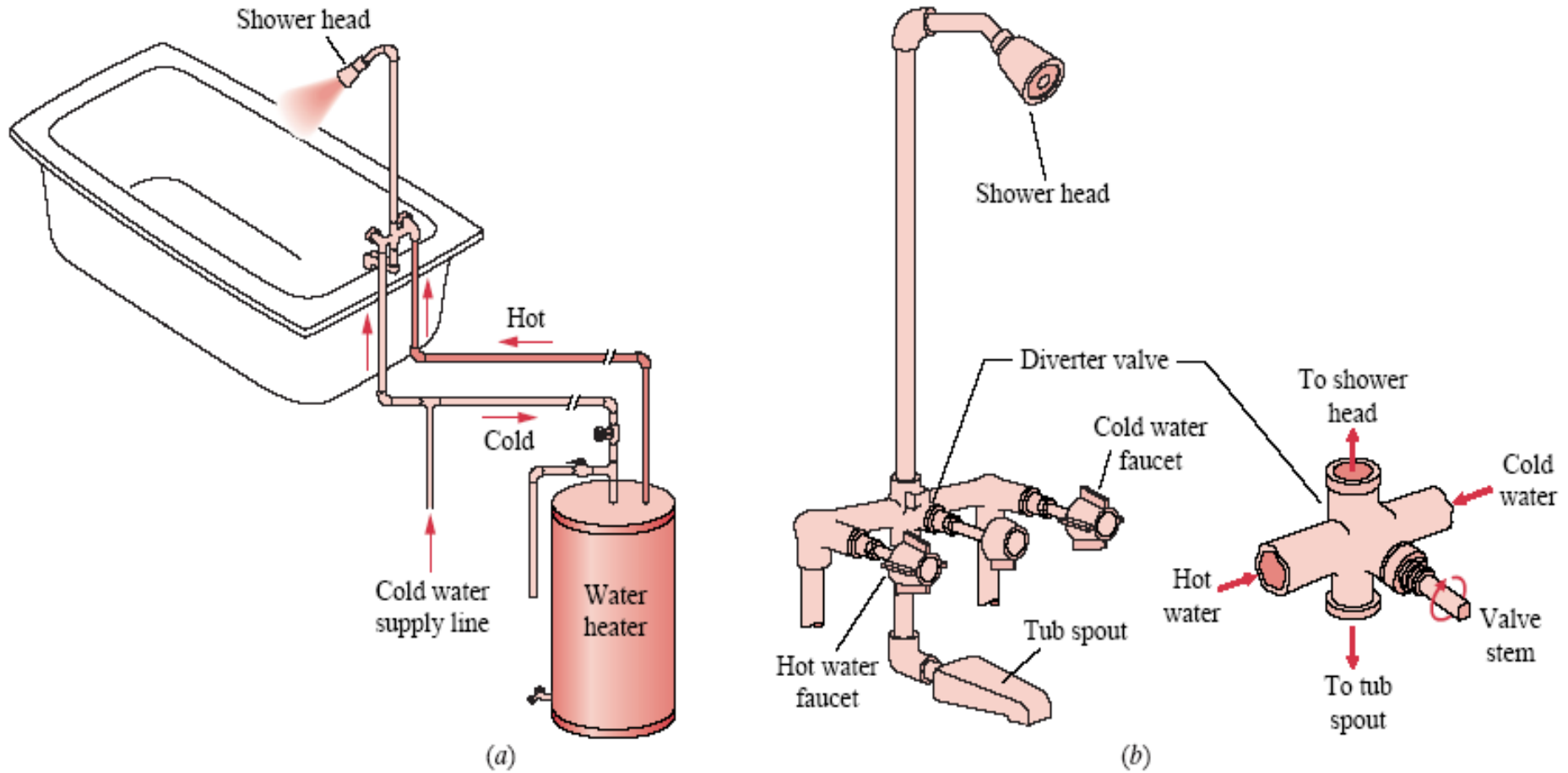

Figure 1.2 Home hot water supply. (a) Overview. (b) Faucet and shower head.

## **FIGURE 1–5**

### **Some application areas of Fluid Mechanics**

- ✓ **Aerodynamics**
- ✓ **Bioengineering and biological systems**
- ✓ **Combustion**
- ✓ **Energy generation**
- ✓ **Geology**
- ✓ **Hydraulics and Hydrology**
- ✓ **Hydrodynamics**
- ✓ **Meteorology**
- ✓ **Ocean and Coastal Engineering**
- ✓ **Water Resources**
- ✓ **...numerous other examples...**

**Thermofluids is beautiful**

## FIGURE 1-5

### Some application areas of Fluid Mechanics, Aerodynamics



# FIGURE 1-5

## Some application areas of Fluid Mechanics, Bioengineering

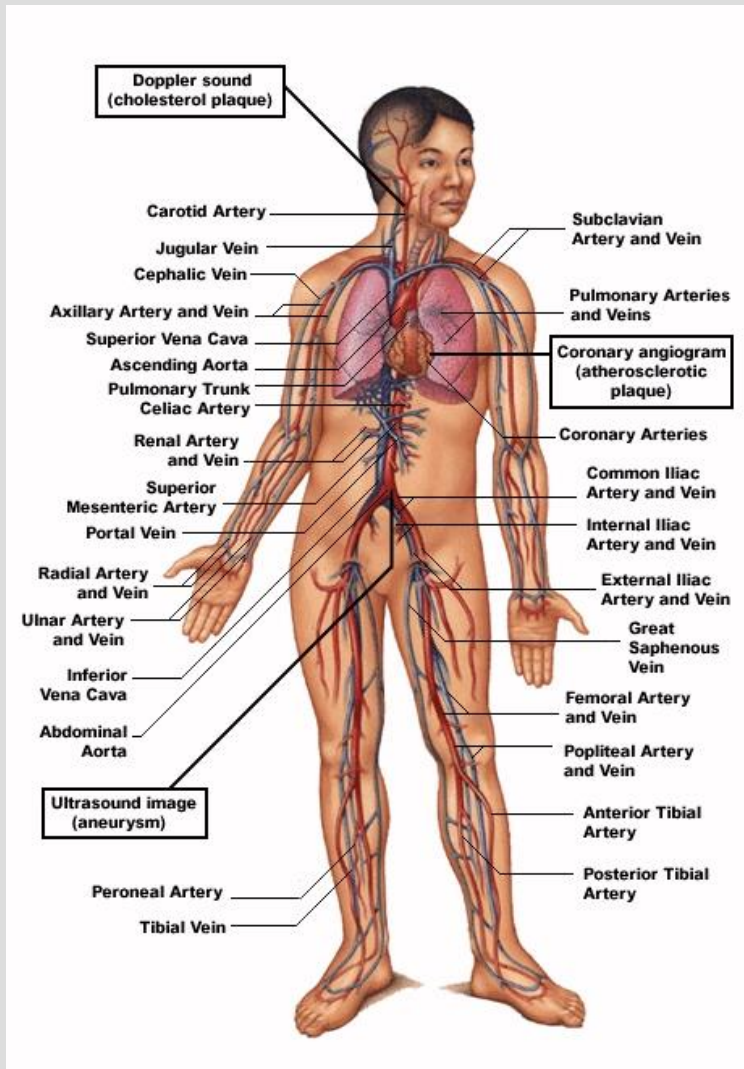

**FIGURE 1-5**  
**Some application areas of Fluid Mechanics,**  
**Energy generation**



**FIGURE 1-5**  
**Some application areas of Fluid Mechanics,**



**FIGURE 1-5**  
**Some application areas of Fluid Mechanics,**  
**Geology**



**FIGURE 1-5**  
**Some application areas of Fluid Mechanics,**  
**River Hydraulics**





**FIGURE 1-5**  
**Some application areas of Fluid Mechanics,  
Hydraulic Structures**



**FIGURE 1-5**  
**Some application areas of Fluid Mechanics,  
Hydrodynamics**



**FIGURE 1-5**  
**Some application areas of Fluid Mechanics,**  
**Meteorology**

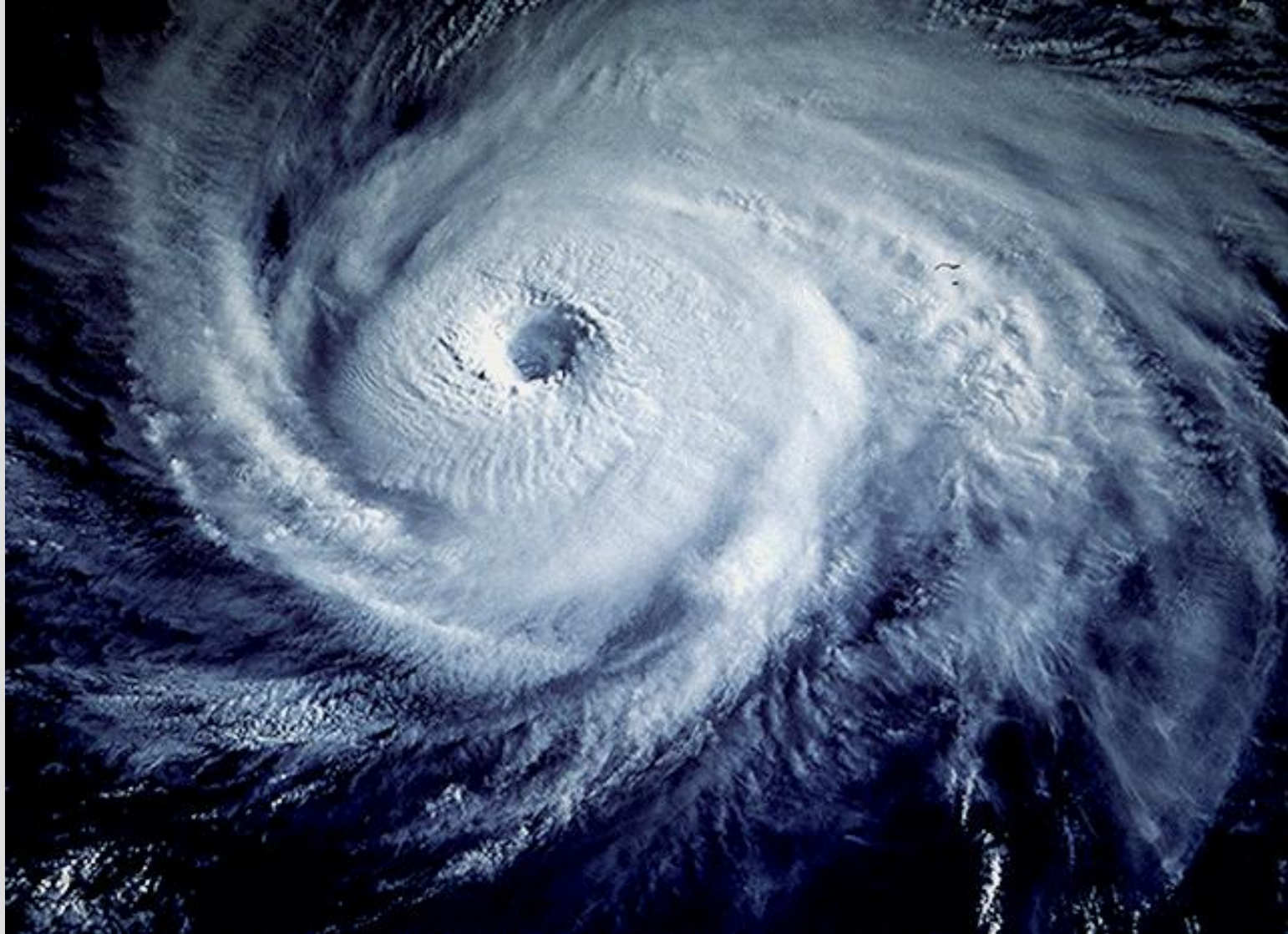

# IMPORTANCE OF DIMENSIONS AND UNITS

- Any physical quantity can be characterized by **dimensions**.
- The magnitudes assigned to the dimensions are called **units**.
- Some basic dimensions such as mass  $m$ , length  $L$ , time  $t$ , and temperature  $T$  are selected as **primary** or **fundamental dimensions**, while others such as velocity  $V$ , energy  $E$ , and volume  $V$  are expressed in terms of the primary dimensions and are called **secondary dimensions**, or **derived dimensions**.
- **Metric SI system**: A simple and logical system based on a decimal relationship between the various units.
- **English system**: It has no apparent systematic numerical base, and various units in this system are related to each other rather arbitrarily.

**TABLE 1-1**

The seven fundamental (or primary) dimensions and their units in SI

Dimension	Unit
Length	meter (m)
Mass	kilogram (kg)
Time	second (s)
Temperature	kelvin (K)
Electric current	ampere (A)
Amount of light	candela (cd)
Amount of matter	mole (mol)

**TABLE 1-2**

Standard prefixes in SI units

Multiple	Prefix
$10^{12}$	tera, T
$10^9$	giga, G
$10^6$	mega, M
$10^3$	kilo, k
$10^2$	hecto, h
$10^1$	deka, da
$10^{-1}$	deci, d
$10^{-2}$	centi, c
$10^{-3}$	milli, m
$10^{-6}$	micro, $\mu$
$10^{-9}$	nano, n
$10^{-12}$	pico, p

# Some SI and English Units

$$1 \text{ lbm} = 0.45359 \text{ kg}$$

$$1 \text{ ft} = 0.3048 \text{ m}$$

$$\text{Work} = \text{Force} \times \text{Distance}$$

$$1 \text{ J} = 1 \text{ N} \cdot \text{m}$$

$$1 \text{ cal} = 4.1868 \text{ J}$$

$$1 \text{ Btu} = 1.0551 \text{ kJ}$$

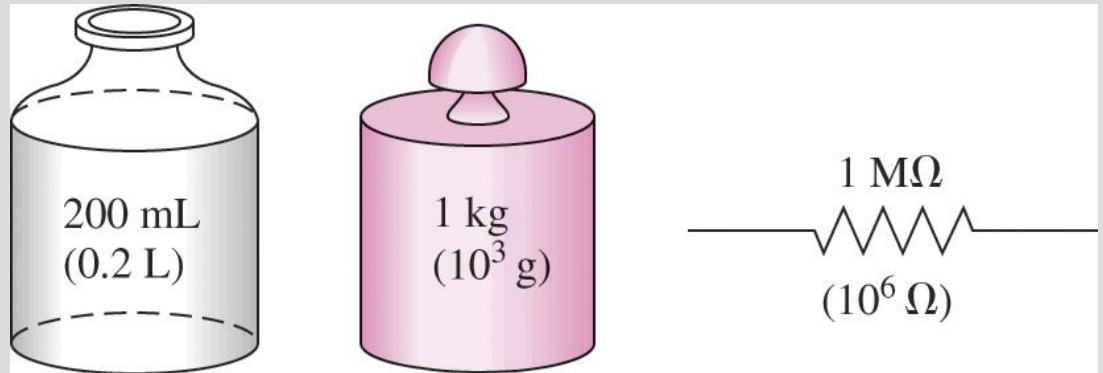

The SI unit prefixes are used in all branches of engineering.

$$\text{Force} = (\text{Mass})(\text{Acceleration})$$

$$F = ma$$

$$1 \text{ N} = 1 \text{ kg} \cdot \text{m}/\text{s}^2$$

$$1 \text{ lbf} = 32.174 \text{ lbm} \cdot \text{ft}/\text{s}^2$$

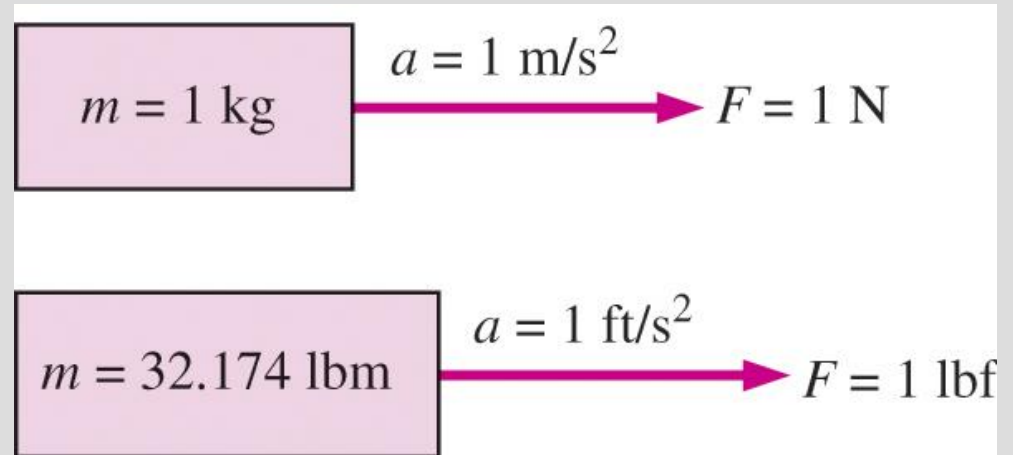

The definition of the force units.

# PROBLEM-SOLVING TECHNIQUE

- Step 1: Problem Statement
- Step 2: Schematic
- Step 3: Assumptions and Approximations
- Step 4: Physical Laws
- Step 5: Properties
- Step 6: Calculations
- Step 7: Reasoning, Verification, and Discussion

## **EES (Engineering Equation Solver)** (Pronounced as ease):

EES is a program that solves systems of linear or nonlinear algebraic or differential equations numerically. It has a large library of built-in thermodynamic property functions as well as mathematical functions. Unlike some software packages, EES does not solve engineering problems; it only solves the equations supplied by the user.

# Accuracy, Precision, and Significant Digits

Engineers must be aware of three principals that govern the proper use of numbers.

- 1. Accuracy error :** Value of one reading minus the true value. Closeness of the average reading to the true value. Generally associated with repeatable, fixed errors.
- 2. Precision error :** Value of one reading minus the average of readings. Is a measure of the fineness of resolution and repeatability of the instrument. Generally associated with random errors.
- 3. Significant digits :** Digits that are relevant and meaningful. When performing calculations, the final result is only as precise as the least precise parameter in the problem. When the number of significant digits is unknown, the accepted standard is 3. Use 3 in all homework and exams.

# A remark on Significant Digits

***Given:***

**Volume:**  $V = 3.75 \text{ L}$

**Density:**  $\rho = 0.845 \text{ kg/L}$

**(3 significant digits)**

***Also,***  $3.75 \times 0.845 = 3.16875$

***Find:***

**Mass:**  $m = \rho V = 3.16875 \text{ kg}$

***Rounding to 3 significant digits:***

**$m = 3.17 \text{ kg}$**

A result with more significant digits than that of given data falsely implies more accuracy.



# SYSTEMS AND CONTROL VOLUMES

- **System:** A quantity of matter or a region in space chosen for study.
- **Surroundings:** The mass or region outside the system
- **Boundary:** The real or imaginary surface that separates the system from its surroundings.
- The boundary of a system can be *fixed* or *movable*.
- Systems may be considered to be *closed* or *open*.
- **Closed system (Control mass):** A fixed amount of mass, and no mass can cross its boundary.

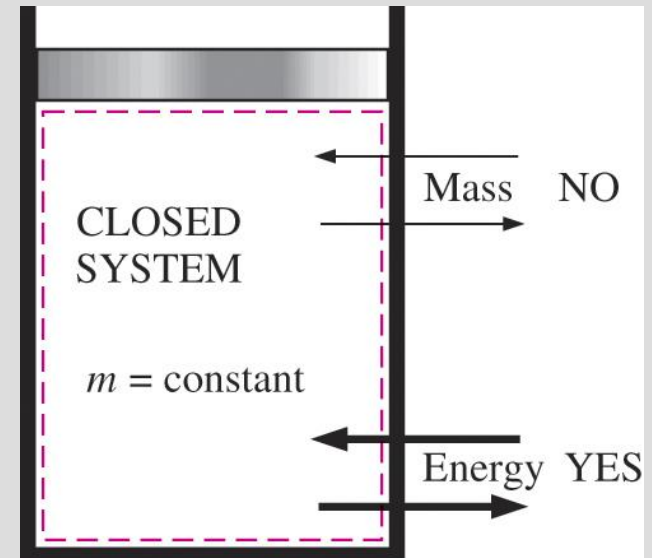
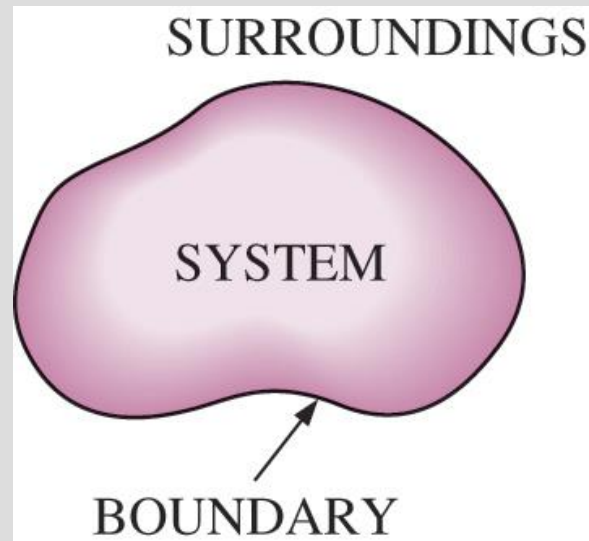
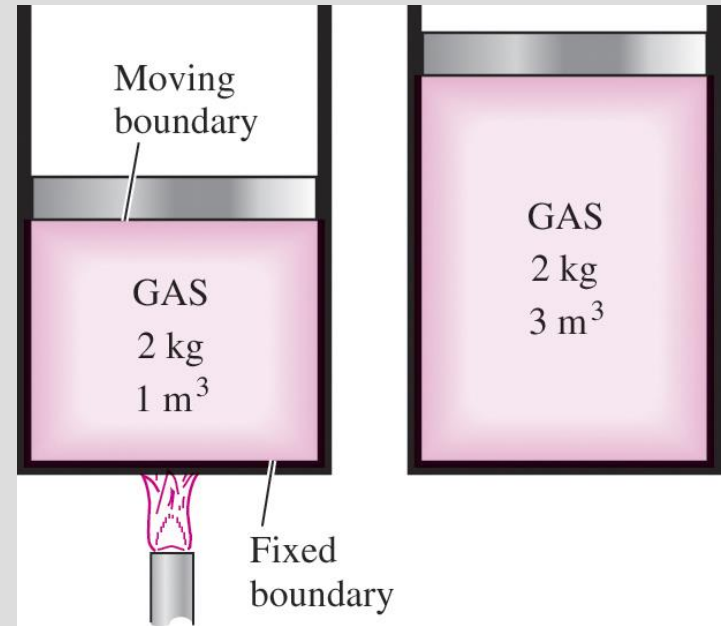

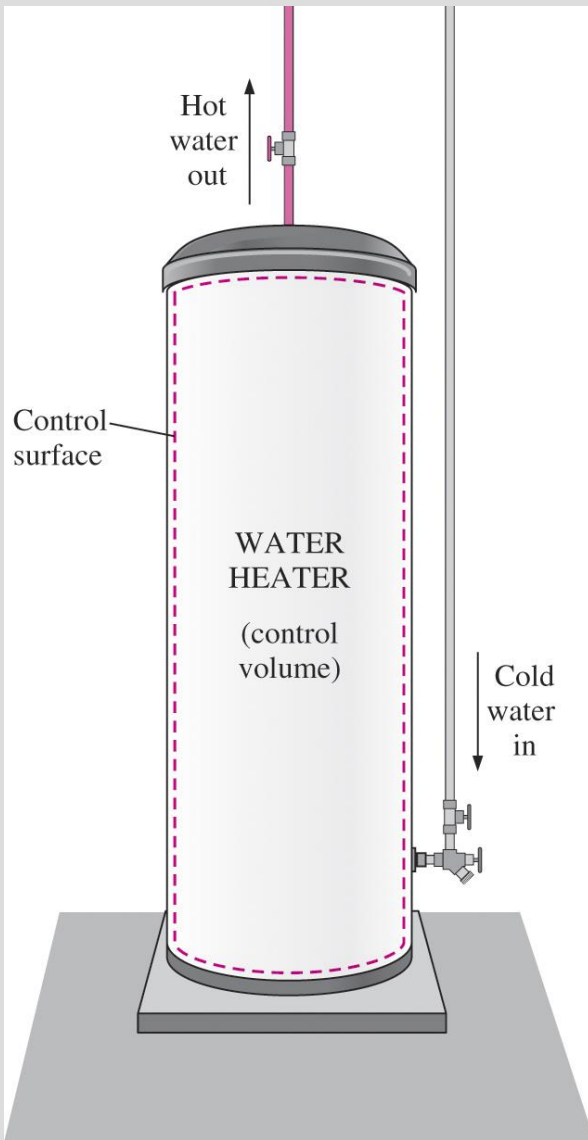

An open system (a control volume) with one inlet and one exit.

- **Open system (control volume):** A properly selected region in space.
- It usually encloses a device that involves mass flow such as a compressor, turbine, or nozzle.
- Both mass and energy can cross the boundary of a control volume.
- **Control surface:** The boundaries of a control volume. It can be real or imaginary.

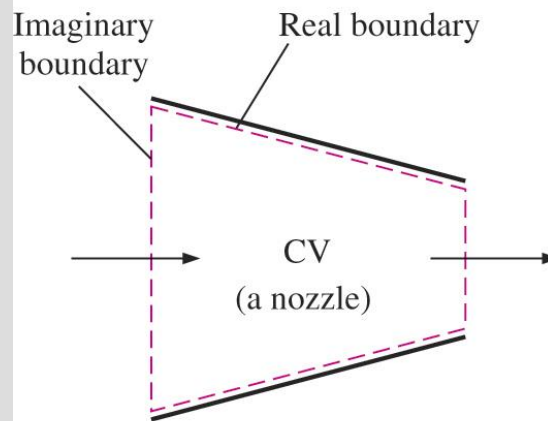

(a) A control volume with real and imaginary boundaries

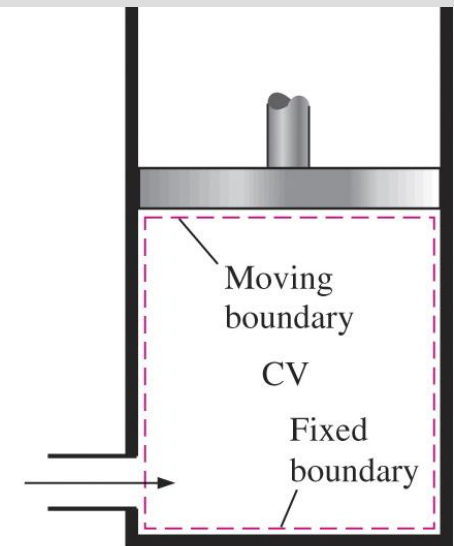

(b) A control volume with fixed and moving boundaries

# PROPERTIES OF A SYSTEM

- **Property:** Any characteristic of a system.
- Some familiar properties are pressure  $P$ , temperature  $T$ , volume  $V$ , and mass  $m$ .
- Properties are considered to be either *intensive* or *extensive*.
- **Intensive properties:** Those that are independent of the mass of a system, such as temperature, pressure, and density.
- **Extensive properties:** Those whose values depend on the size—or extent—of the system.
- **Specific properties:** Extensive properties per unit mass.

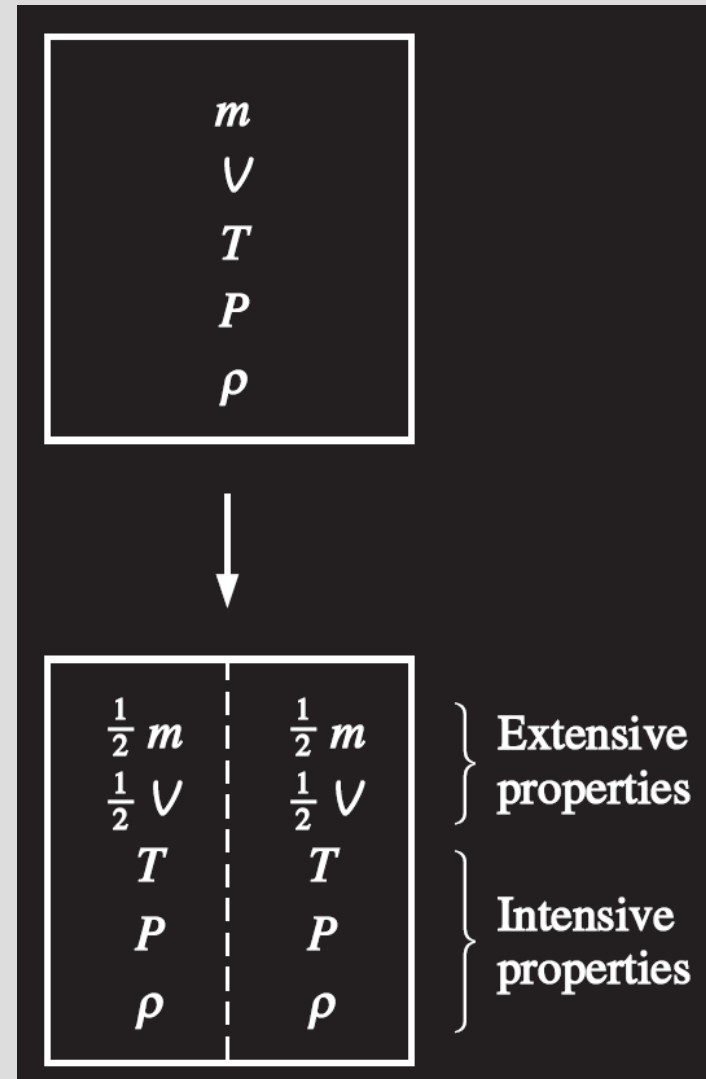

Criterion to differentiate intensive and extensive properties.

# Continuum

- Matter is made up of atoms that are widely spaced in the gas phase. Yet it is very convenient to disregard the atomic nature of a substance and view it as a continuous, homogeneous matter with no holes, that is, a **continuum**.
- The continuum idealization allows us to treat properties as point functions and to assume the properties vary continually in space with no jump discontinuities.
- This idealization is valid as long as the size of the system we deal with is large relative to the space between the molecules.
- This is the case in practically all problems.
- In this text we will limit our consideration to substances that can be modeled as a continuum.

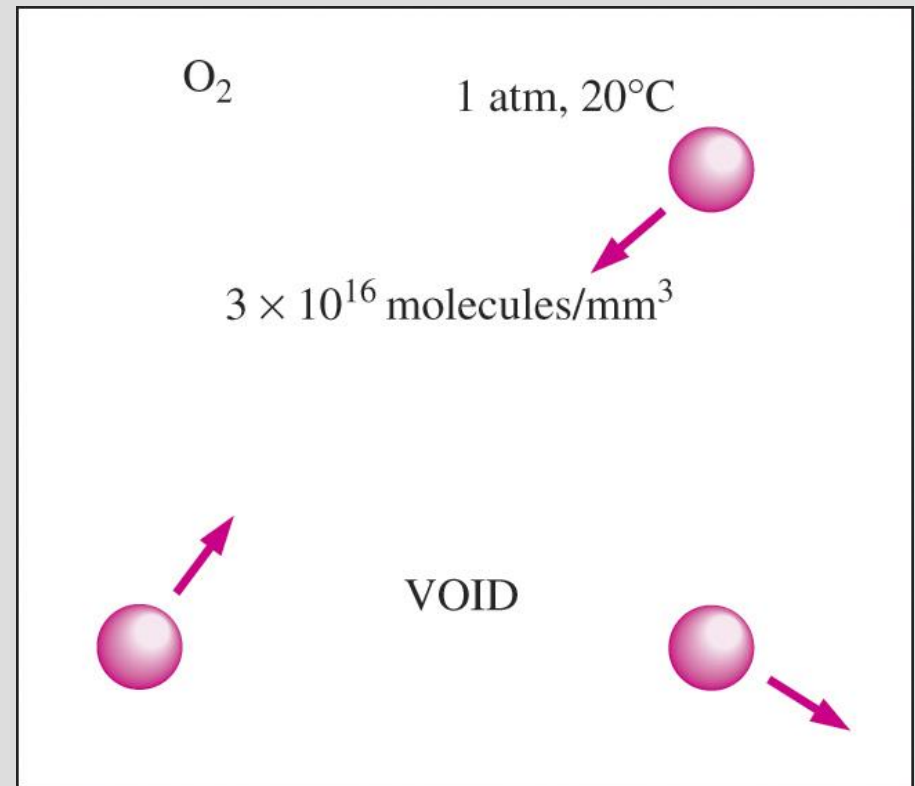

Despite the large gaps between molecules, a substance can be treated as a continuum because of the very large number of molecules even in an extremely small volume.

- Quiz:
- Definir los tipos de propiedades que describen un sistema.

# What is a fluid?

- A fluid is a substance in the gaseous or liquid form
- Distinction between solid and fluid?
  - ✓ Solid: can resist an applied shear by deforming. Stress is proportional to strain
  - ✓ Fluid: deforms continuously under applied shear. Stress is proportional to strain rate

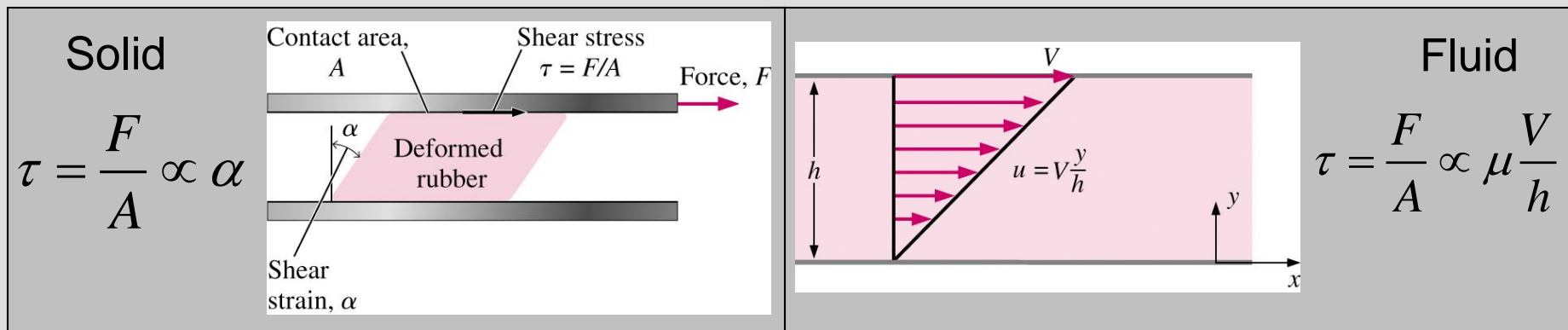

# What is a fluid?

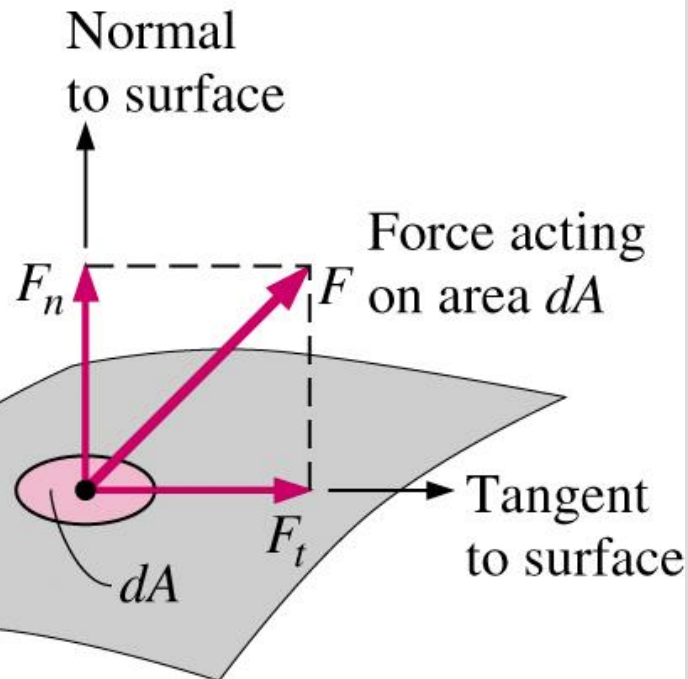

- Stress is defined as the force per unit area.
- Normal component: normal stress
  - ✓ In a fluid at rest, the normal stress is called **pressure**
- Tangential component: shear stress

# What is a fluid?

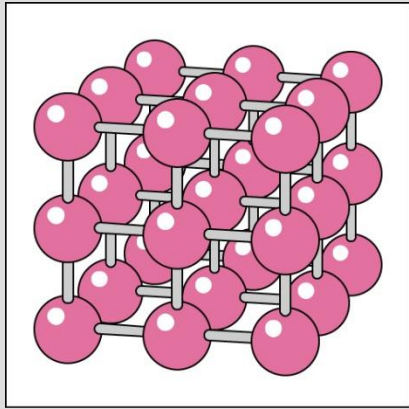

(a)

solid

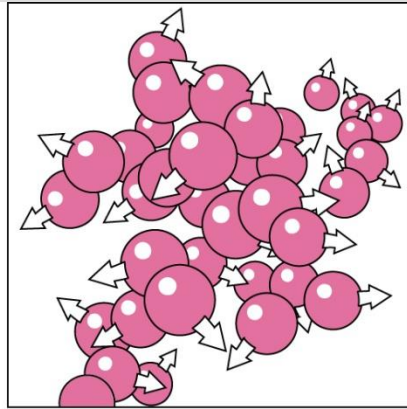

(b)

liquid

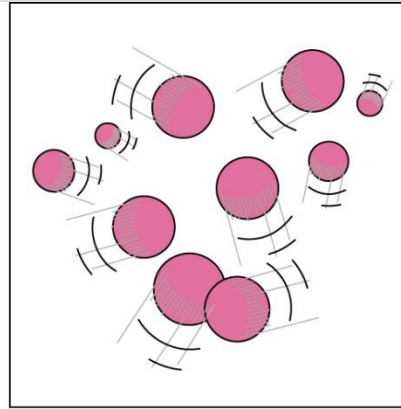

(c)

gas

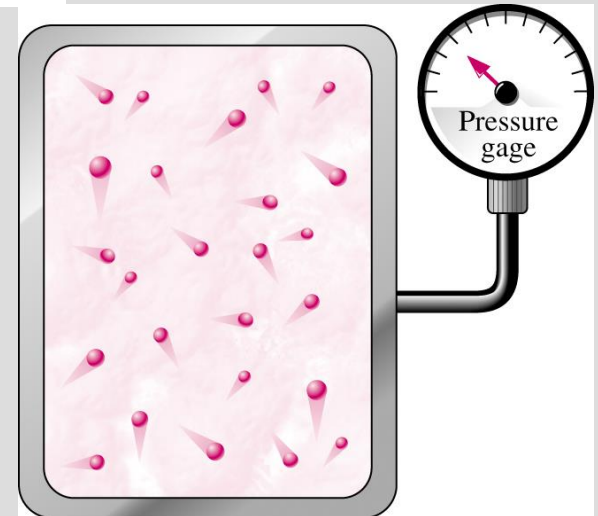



# STATE AND EQUILIBRIUM

- Thermodynamics deals with *equilibrium* states.
- **Equilibrium:** A state of balance.
- In an equilibrium state there are no unbalanced potentials (or driving forces) within the system.
- **Thermal equilibrium:** If the temperature is the same throughout the entire system.
- **Mechanical equilibrium:** If there is no change in pressure at any point of the system with time.
- **Phase equilibrium:** If a system involves two phases and when the mass of each phase reaches an equilibrium level and stays there.
- **Chemical equilibrium:** If the chemical composition of a system does not change with time, that is, no chemical reactions occur.

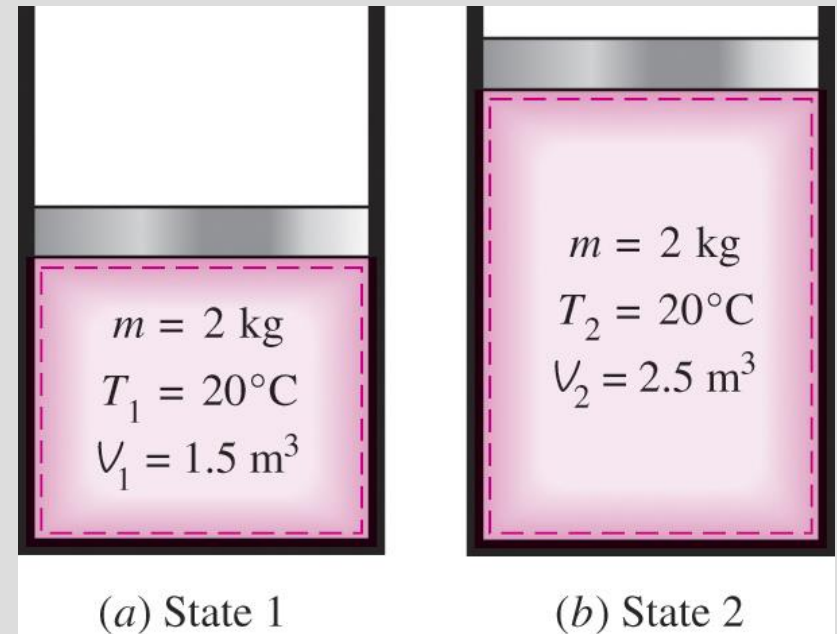

A system at two different states.

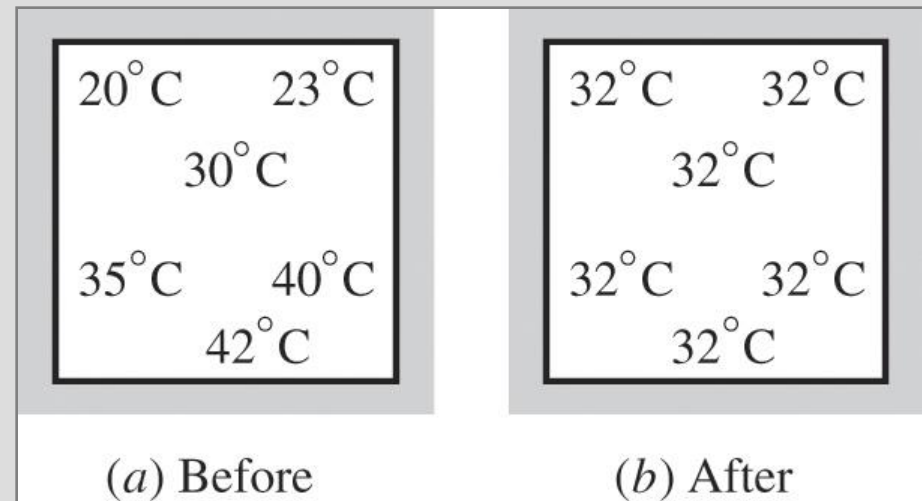

A closed system reaching thermal equilibrium.

# The State Postulate

- The number of properties required to fix the state of a system is given by the **state postulate**:
  - ✓ *The state of a simple compressible system is completely specified by two independent, intensive properties.*
- **Simple compressible system**: If a system involves no electrical, magnetic, gravitational, motion, and surface tension effects.



The state of nitrogen is fixed by two independent, intensive properties.

# PROCESSES AND CYCLES

**Process:** Any change that a system undergoes from one equilibrium state to another.

**Path:** The series of states through which a system passes during a process.

To describe a process completely, one should specify the initial and final states, as well as the path it follows, and the interactions with the surroundings.

**Quasistatic or quasi-equilibrium process:** When a process proceeds in such a manner that the system remains infinitesimally close to an equilibrium state at all times.

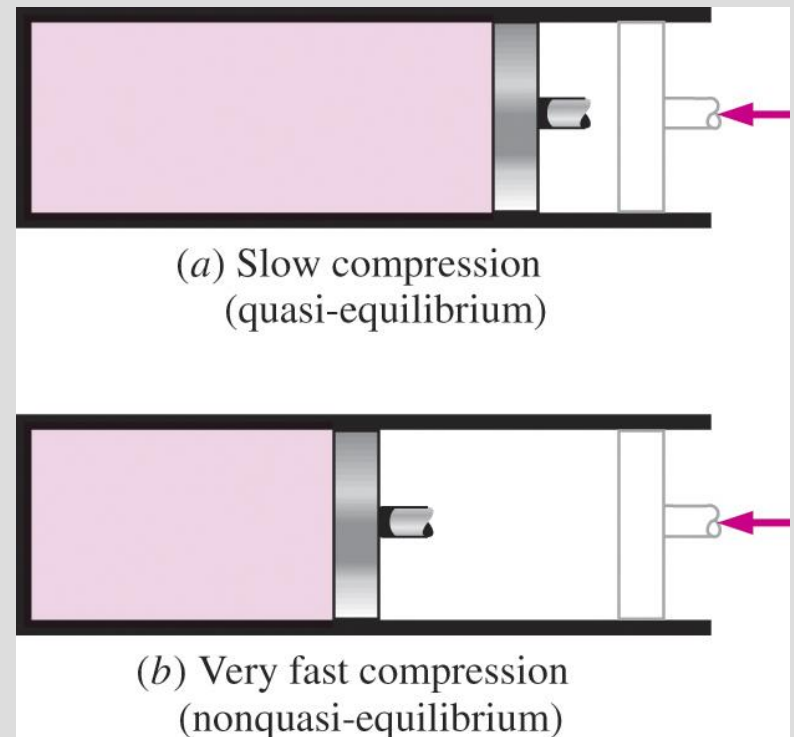
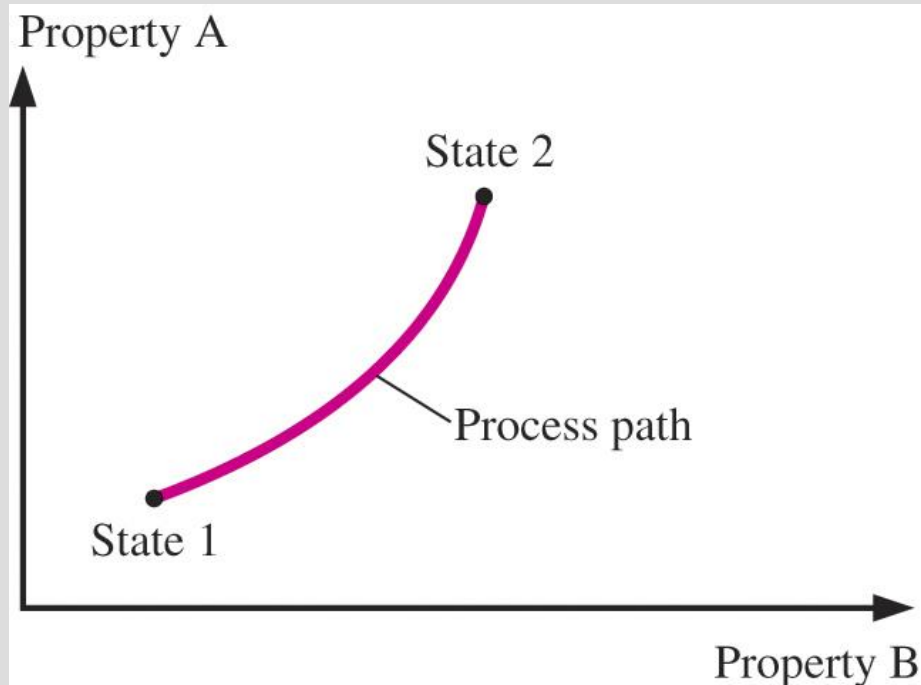

- Process diagrams plotted by employing thermodynamic properties as coordinates are very useful in visualizing the processes.
- Some common properties that are used as coordinates are temperature  $T$ , pressure  $P$ , and volume  $V$  (or specific volume  $v$ ).
- The prefix *iso-* is often used to designate a process for which a particular property remains constant.
- **Isothermal process:** A process during which the temperature  $T$  remains constant.
- **Isobaric process:** A process during which the pressure  $P$  remains constant.
- **Isochoric (or isometric) process:** A process during which the specific volume  $v$  remains constant.
- **Cycle:** A process during which the initial and final states are identical.

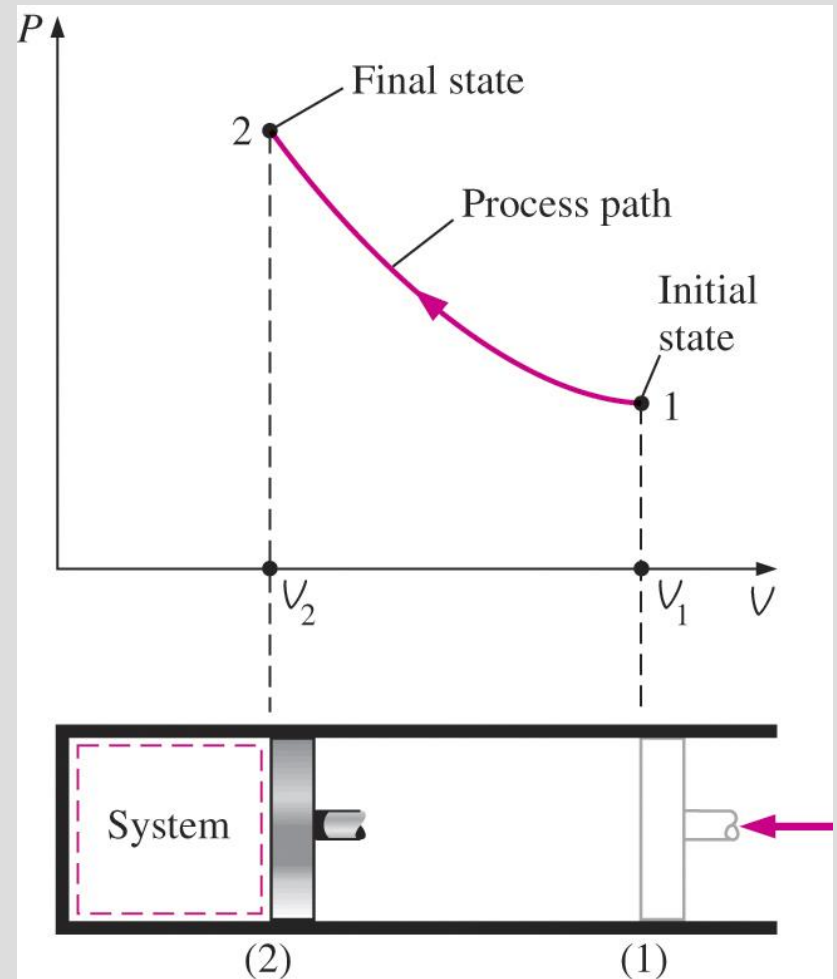

The  $P$ - $V$  diagram of a compression process.

# The Steady-Flow Process

- The term *steady* implies *no change with time*. The opposite of steady is *unsteady*, or *transient*.
- A large number of engineering devices operate for long periods of time under the same conditions, and they are classified as *steady-flow devices*.
- **Steady-flow process:** A process during which a fluid flows through a control volume steadily.
- Steady-flow conditions can be closely approximated by devices that are intended for continuous operation such as **turbines, pumps, boilers, condensers, and heat exchangers or power plants or refrigeration systems.**

During a steady-flow process, fluid properties within the control volume may change with position but not with time.

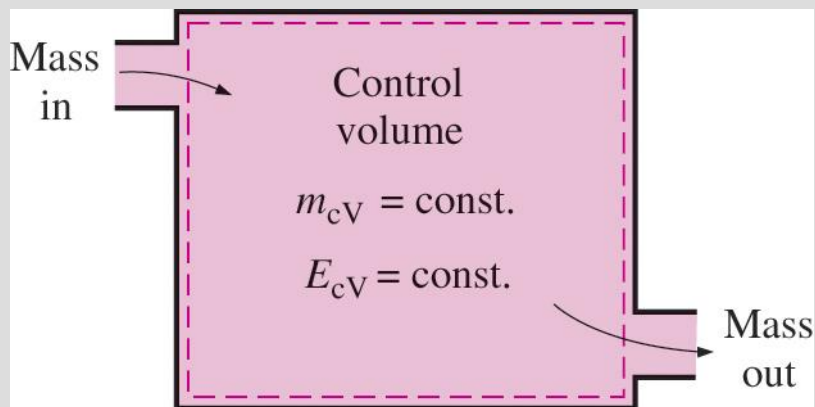
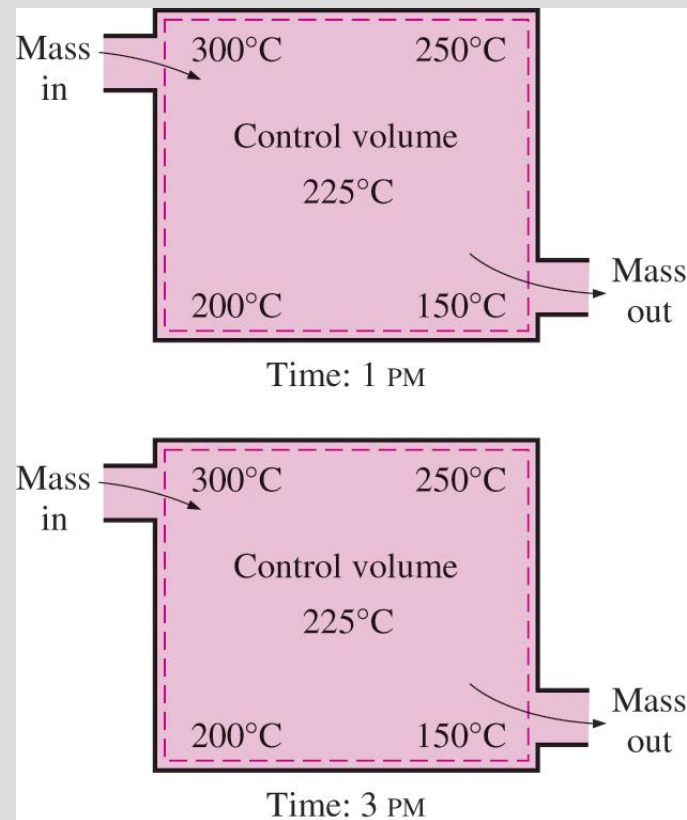

Under steady-flow conditions, the mass and energy contents of a control volume remain constant.

# PROPERTIES OF THE FLUIDS

# Density

The density of a fluid, denoted by  $\rho$ , is its mass per unit volume. Density is highly variable in gases and increases nearly proportionally to the pressure level. Density in liquids is nearly constant; the density of water (about 1000 kg/m<sup>3</sup>) increases only 1 percent if the pressure is increased by a factor of 220. Thus most liquid flows are treated analytically as nearly incompressible.

$$\rho = \frac{m}{V} \quad (\text{kg}/\text{m}^3)$$

$$m = \text{masa, kg}$$

$$V = \text{volumen, } \text{m}^3$$

# Density of Ideal Gases

- **Equation of State:** equation for the relationship between pressure, temperature, and density.
- The simplest and best-known equation of state is the ideal-gas equation.

$$P v = R T \quad \text{or} \quad P = \rho R T$$

- Ideal-gas equation holds for most gases.
- However, dense gases such as water vapor and refrigerant vapor should not be treated as ideal gases.



# Specific weight

The specific weight of a fluid, denoted by  $\gamma$ , is its weight per unit volume. Just as a mass a weight  $W = mg$ , density and specific weight are simply related by gravity

$$\gamma = \rho g \quad (N/m^3)$$

$$\rho = \text{densidad, } kg / m^3$$

$$g = \text{aceleración de la gravedad, } m / s^2$$

$$\gamma_{air} = (1,205 kg/m^3)(9,807 m/s^2) = 11,8 N/m^3 = 0,0752 lbf / ft^3$$

$$\gamma_{water} = (998 kg/m^3)(9,807 m/s^2) = 9790 N/m^3 = 62,4 lbf / ft^3$$

# Specific gravity

The specific gravity, denoted by SG, is the ratio of a fluid density to a standard reference fluid, water (for liquids), and air (for gases)

$$SG_{gas} = \frac{\rho_{gas}}{\rho_{air}} = \frac{\rho_{gas}}{1,205 \text{ kg/m}^3}$$

$$SG_{liquid} = \frac{\rho_{liquid}}{\rho_{water}} = \frac{\rho_{liquid}}{998 \text{ kg/m}^3}$$

For example, the specific gravity of mercury (Hg) is  $SG_{Hg} = 13580/998 \approx 13,6$ . These dimensionless ratios are easier to remember than the actual numerical values of density of a variety of fluids

# DENSITY AND SPECIFIC GRAVITY

$$\begin{aligned} V &= 12 \text{ m}^3 \\ m &= 3 \text{ kg} \\ \Downarrow \\ \rho &= 0.25 \text{ kg/m}^3 \\ \nu &= \frac{1}{\rho} = 4 \text{ m}^3/\text{kg} \end{aligned}$$

Density is mass per unit volume;  
specific volume is volume per  
unit mass.

Specific gravities of some  
substances at 0°C

Substance	SG
Water	1.0
Blood	1.05
Seawater	1.025
Gasoline	0.7
Ethyl alcohol	0.79
Mercury	13.6
Wood	0.3–0.9
Gold	19.2
Bones	1.7–2.0
Ice	0.92
Air (at 1 atm)	0.0013

# Vapor Pressure and Cavitation

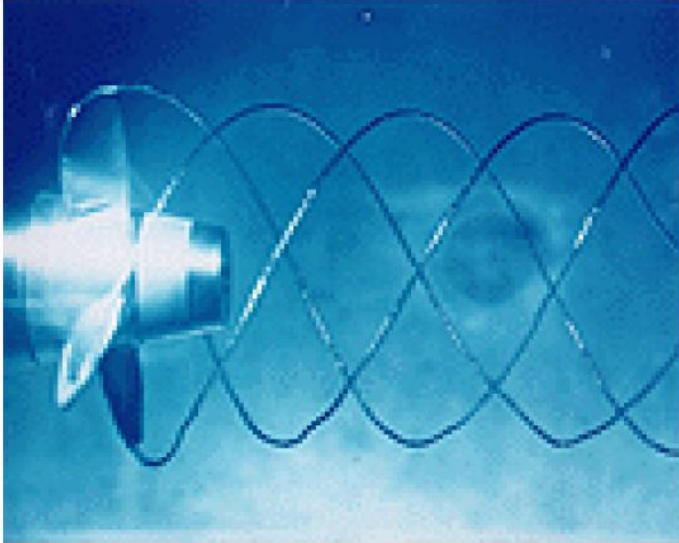

- **Vapor Pressure**  $P_v$  is defined as *the pressure exerted by its vapor in phase equilibrium with its liquid at a given temperature*
- If  $P$  drops below  $P_v$ , liquid is locally vaporized, creating cavities of vapor.
- Vapor cavities collapse when local  $P$  rises above  $P_v$ .
- Collapse of cavities is a violent process which can damage machinery.
- Cavitation is noisy, and can cause structural vibrations.

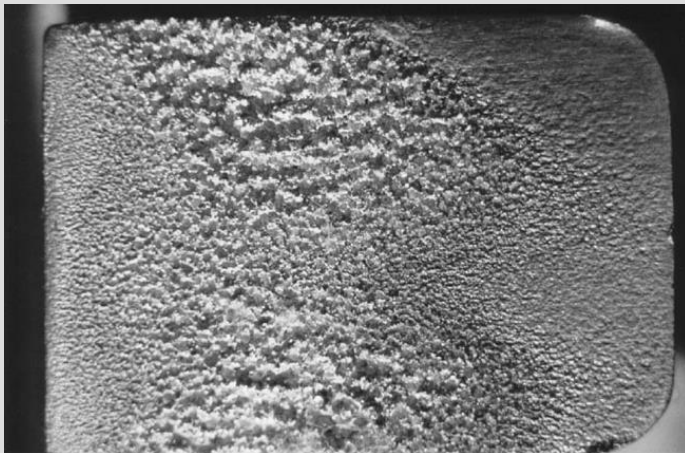

# Vapor Pressure and Cavitation

Saturation (or vapor) pressure of water at various temperatures

## Cavitación

Temperature $T, ^\circ\text{C}$	Saturation Pressure $P_{\text{sat}}, \text{kPa}$
-10	0.260
-5	0.403
0	0.611
5	0.872
10	1.23
15	1.71
20	2.34
25	3.17
30	4.25
40	7.38
50	12.35
100	101.3 (1 atm)
150	475.8
200	1554
250	3973
300	8581

# Coefficient of Compressibility

- How does fluid volume change with  $P$  and  $T$ ?
- Fluids expand as  $T \uparrow$  or  $P \downarrow$
- Fluids contract as  $T \downarrow$  or  $P \uparrow$
- Need fluid properties that relate volume changes to changes in  $P$  and  $T$ .
  - ✓ Coefficient of compressibility

$$\kappa = -v \left( \frac{\partial P}{\partial v} \right)_T = \rho \left( \frac{\partial P}{\partial \rho} \right)_T \quad \text{Approximately in terms of finite changes as:} \quad \kappa \cong -\frac{\Delta P}{\Delta V/V} \cong \frac{\Delta P}{\Delta \rho/\rho} \quad (T=Cte)$$

- ✓ Coefficient of volume expansion

$$\beta = \frac{1}{v} \left( \frac{\partial v}{\partial T} \right)_P = -\frac{1}{\rho} \left( \frac{\partial \rho}{\partial T} \right)_P \quad \text{Approximately in terms of finite changes as:} \quad \beta \cong \frac{\Delta V/V}{\Delta T} \cong -\frac{\Delta \rho/\rho}{\Delta T} \quad (P=Cte)$$

- Combined effects of  $P$  and  $T$  can be written as

$$dv = \left( \frac{\partial v}{\partial T} \right)_P dT + \left( \frac{\partial v}{\partial P} \right)_T dP$$

# Surface Tension

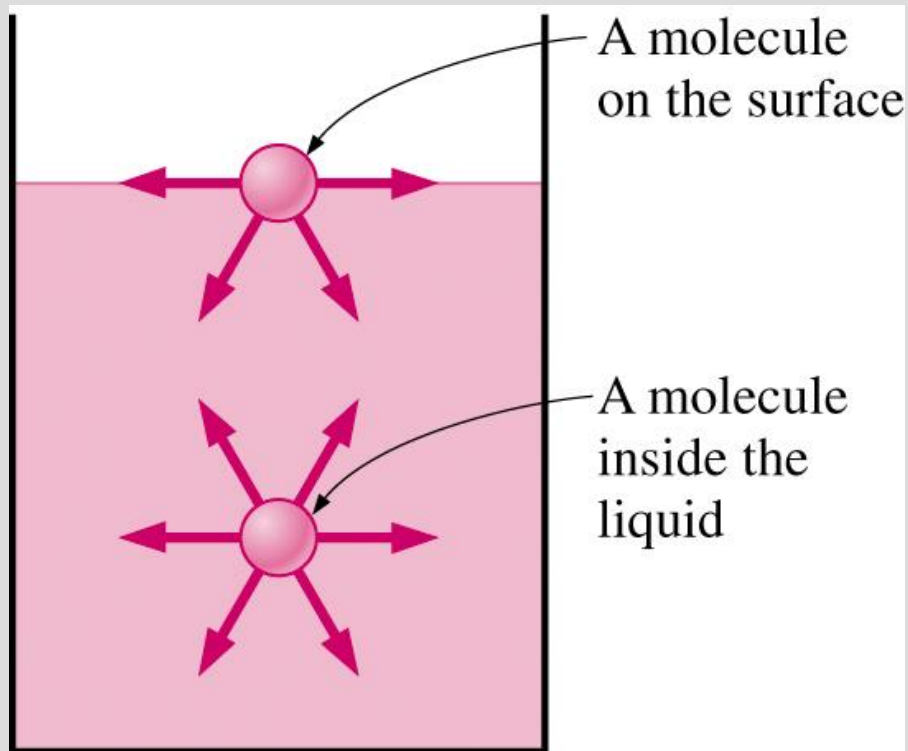

- Liquid droplets behave like small spherical balloons filled with liquid, and the surface of the liquid acts like a stretched elastic membrane under tension.
- The pulling force that causes this is
  - ✓ due to the attractive forces between molecules
  - ✓ called **surface tension**  $\sigma_s$ .
- Attractive force on surface molecule is not symmetric.
- Repulsive forces from interior molecules causes the liquid to minimize its surface area and attain a spherical shape.

# Surface tension ( $\sigma_s$ ) & Capillary effect

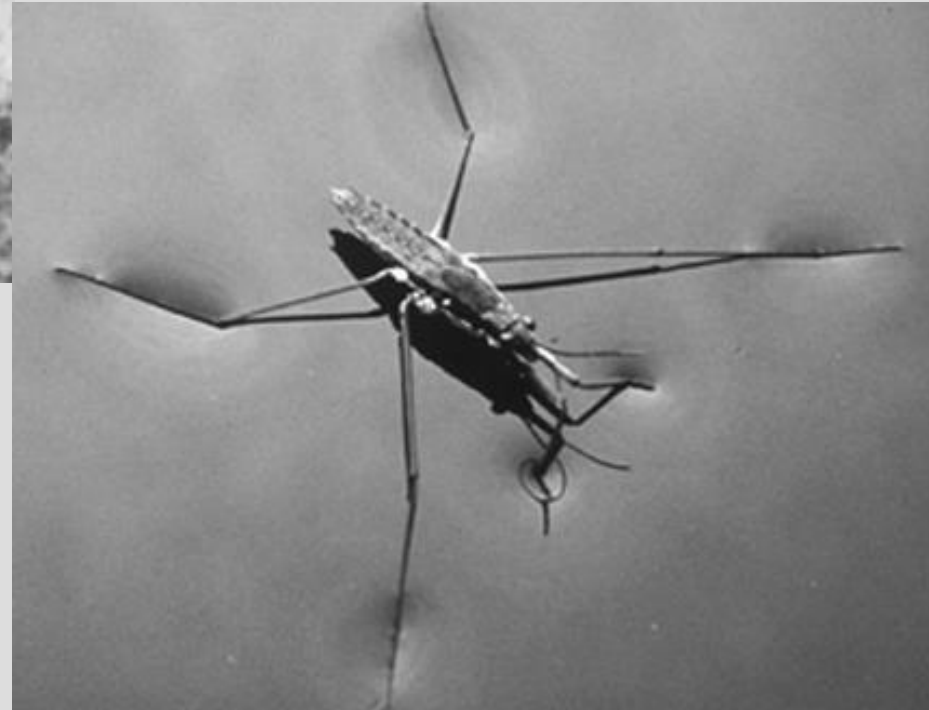



# Capillary Effect

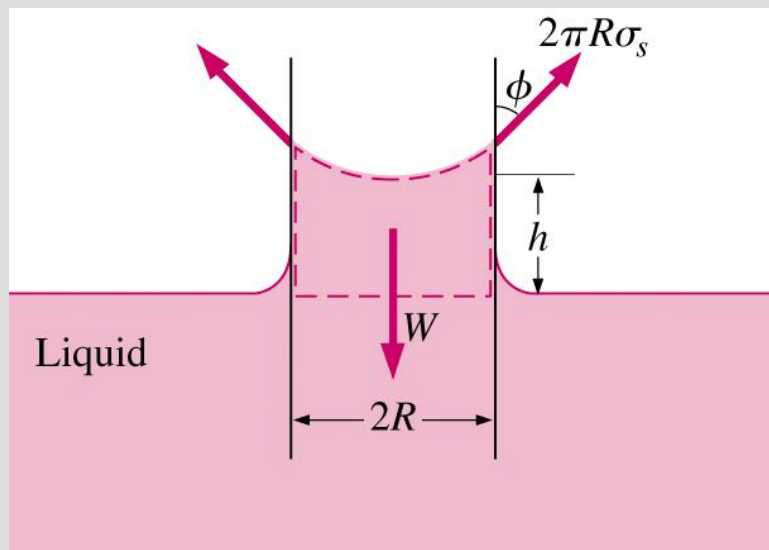
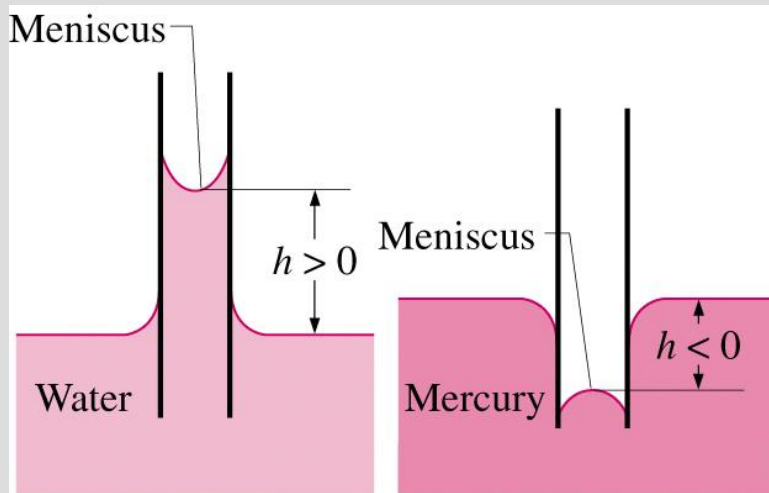

- **Capillary effect** is the rise or fall of a liquid in a small-diameter tube.
- The curved free surface in the tube is called the **meniscus**.
- Water meniscus curves up because water is a *wetting fluid*.
- Mercury meniscus curves down because mercury is a *nonwetting fluid*.
- Force balance can describe magnitude of capillary rise.

# Ejemplos:

- 1.) Determine the density, specific gravity, and mass of the air in a room whose dimensions are 4 m × 5 m × 6 m at 100 kPa and 25°C

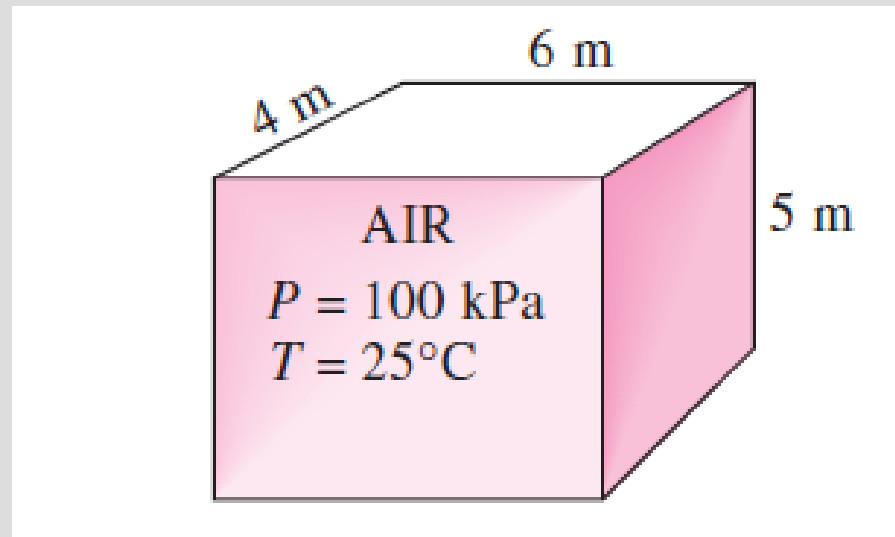

$$R_{air} = 0,287 \text{ KJ/Kg.K}$$

# Quiz:

¿Cuál sería el volumen de mercurio ( $s=13,6$ ) que tendría un peso igual al de  $0.023 \text{ m}^3$  de aceite de ricino, cuyo peso específico es de  $9.42 \text{ kN/m}^3$ ?

# Viscosity

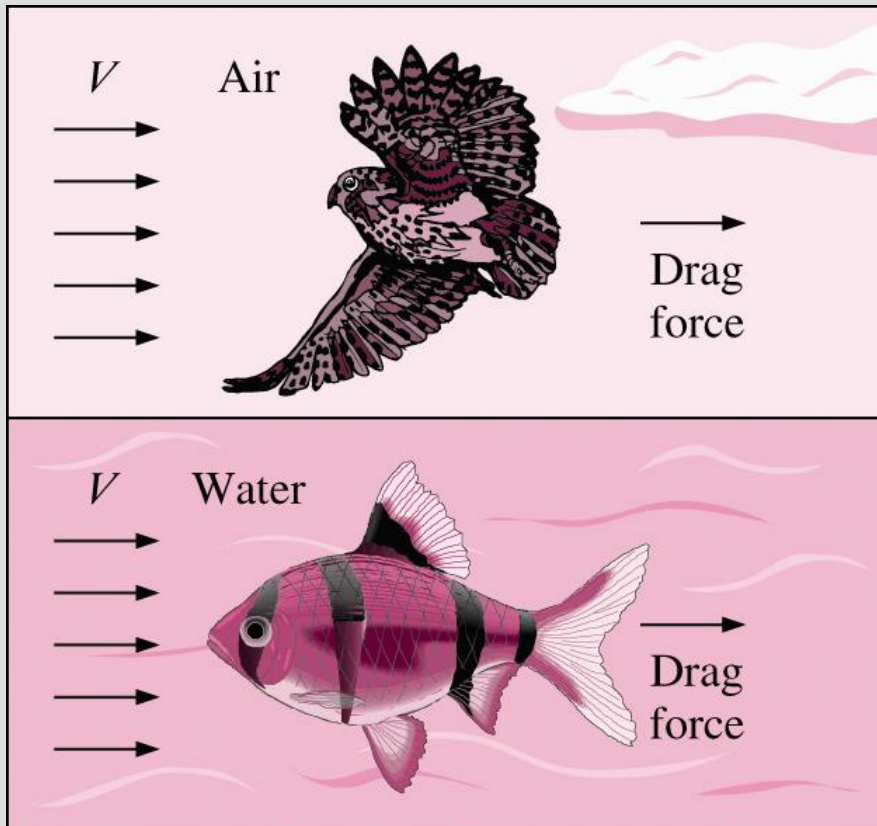

- **Viscosity** is a property that represents the internal resistance of a fluid to motion.
- The force a flowing fluid exerts on a body in the flow direction is called the **drag force**, and the magnitude of this force depends, in part, on viscosity.

# Viscosity

When a fluid is sheared, it begins to move at a strain rate inversely proportional to a property called its coefficient of viscosity  $\mu$ .

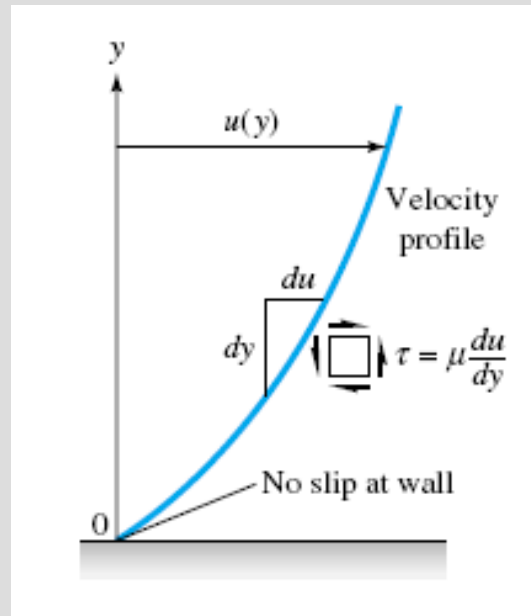
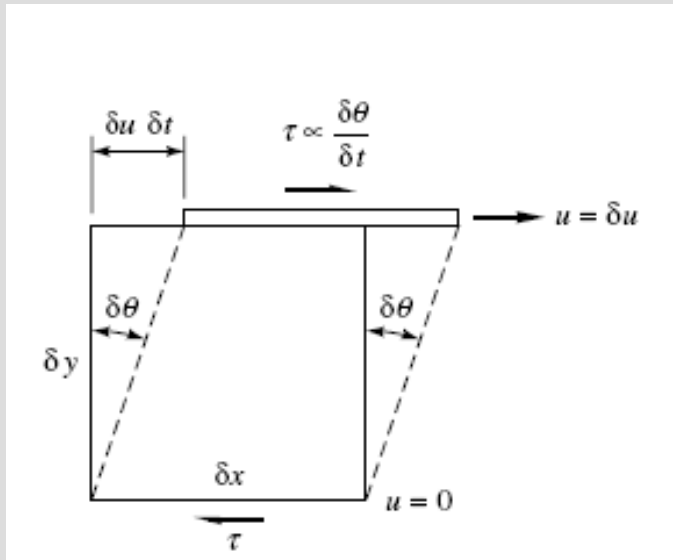

$$\tau \propto \frac{\delta\theta}{\delta t}$$

$$\tan \delta\theta = \frac{\delta u \delta t}{\delta y}$$

$$\frac{d\theta}{dt} = \frac{du}{dy}$$

$$\tau = \mu \frac{d\theta}{dt} = \mu \frac{du}{dy}$$

# Viscosity

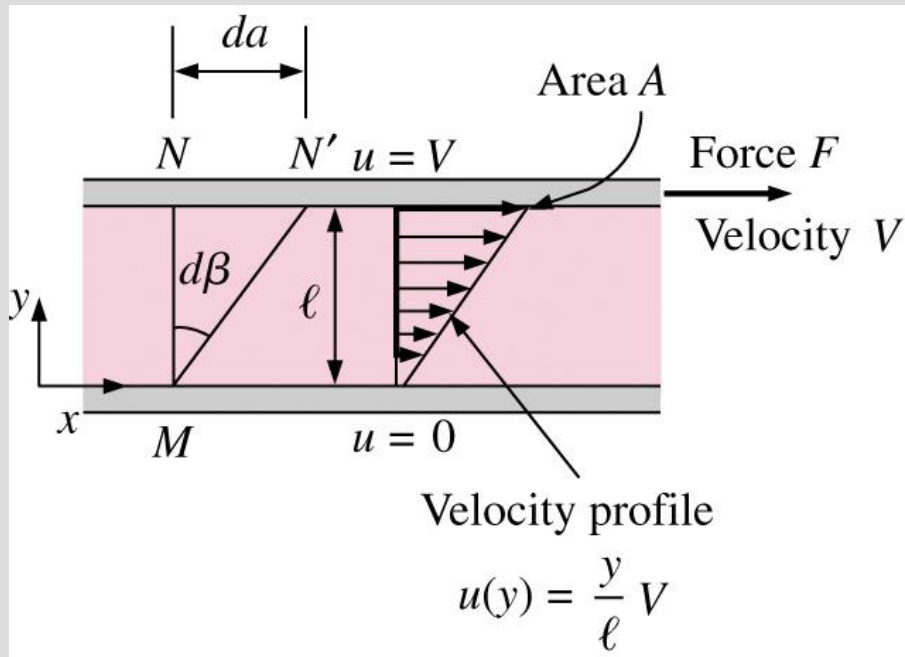

- To obtain a relation for viscosity, consider a fluid layer between two very large parallel plates separated by a distance  $\ell$
- Definition of shear stress is  $\tau = F/A$ .
- Using the no-slip condition,  $u(0) = 0$  and  $u(\ell) = V$ , the velocity profile and gradient are  $u(y) = Vy/\ell$  and  $du/dy = V/\ell$
- Shear stress for Newtonian fluid:  $\tau = \mu du/dy$
- $\mu$  is the **dynamic viscosity** and has units of  $kg/m \cdot s$ ,  $Pa \cdot s$ , or **poise**.

# Viscosimetry

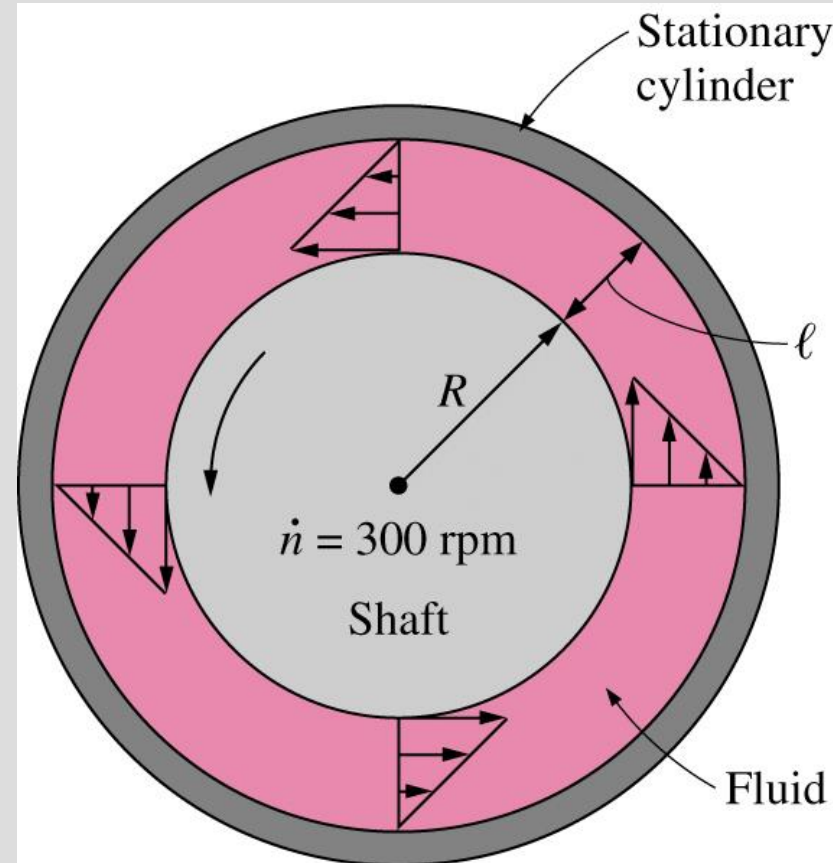

- How is viscosity measured? A rotating viscometer.
  - ✓ Two concentric cylinders with a fluid in the small gap  $\ell$ .
  - ✓ Inner cylinder is rotating, outer one is fixed.

- Use definition of shear force:

$$F = \tau A = \mu A \frac{du}{dy}$$

- If  $\ell/R \ll 1$ , then cylinders can be modeled as flat plates.
- Torque  $T = FR$ , and tangential velocity  $V = \omega R$
- Wetted surface area  $A = 2\pi RL$ .
- Measure  $T$  and  $\omega$  to compute  $\mu$

# Viscosity

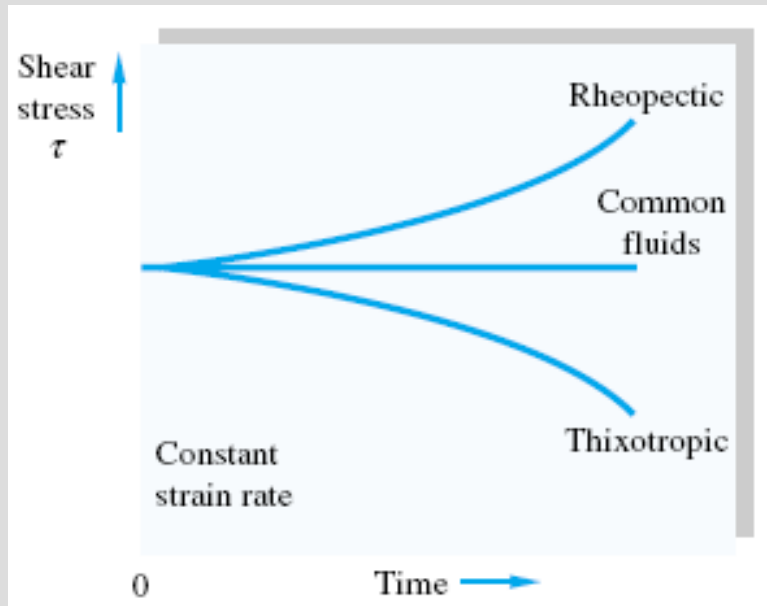
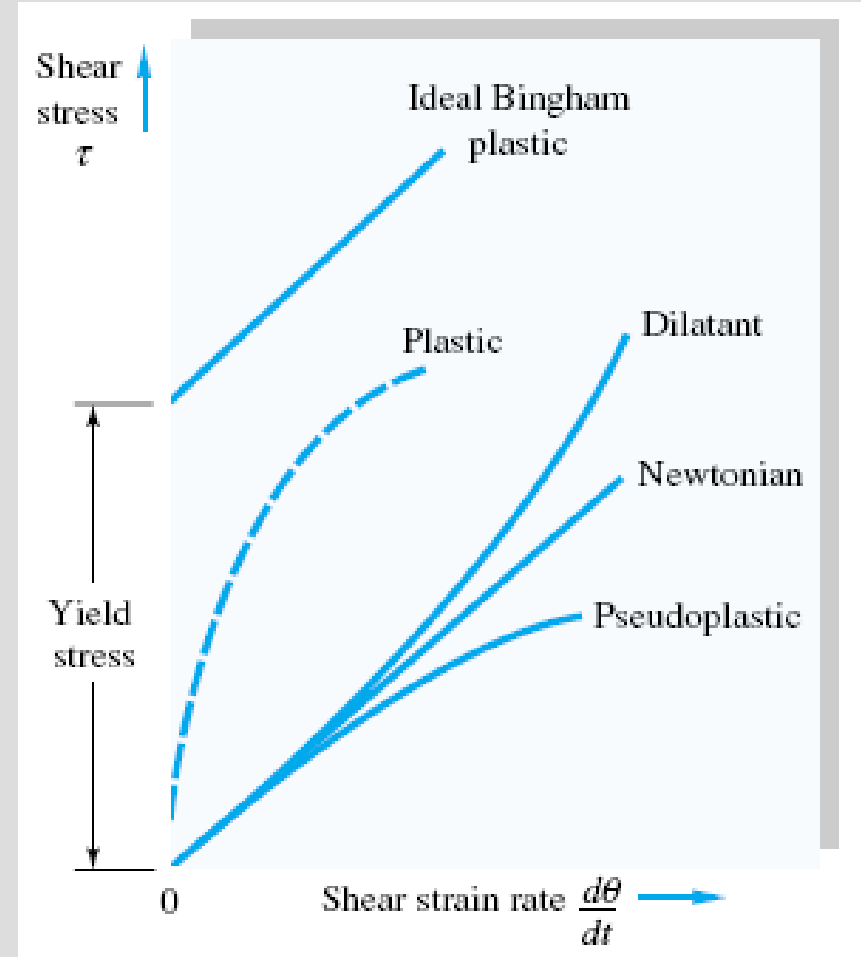
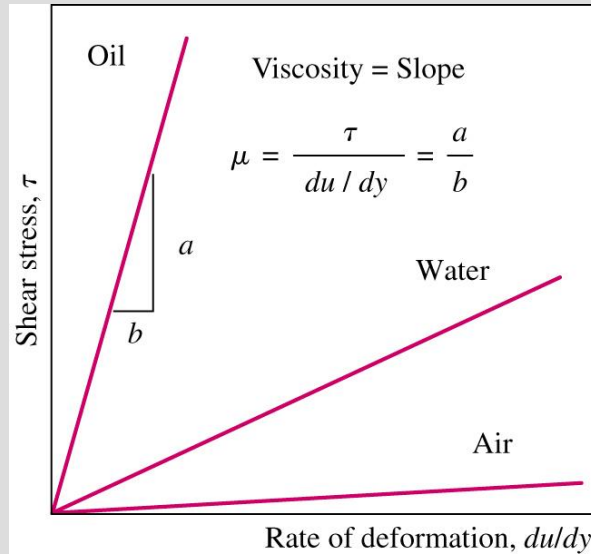



# Viscosity

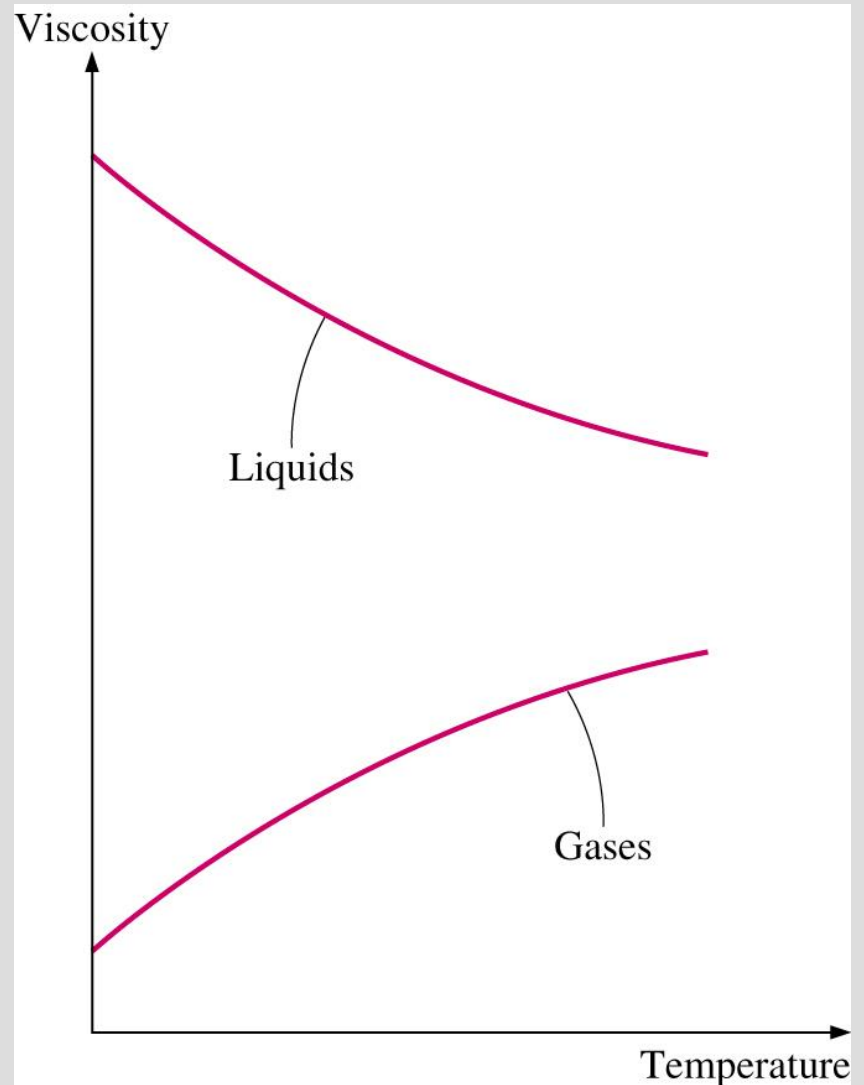
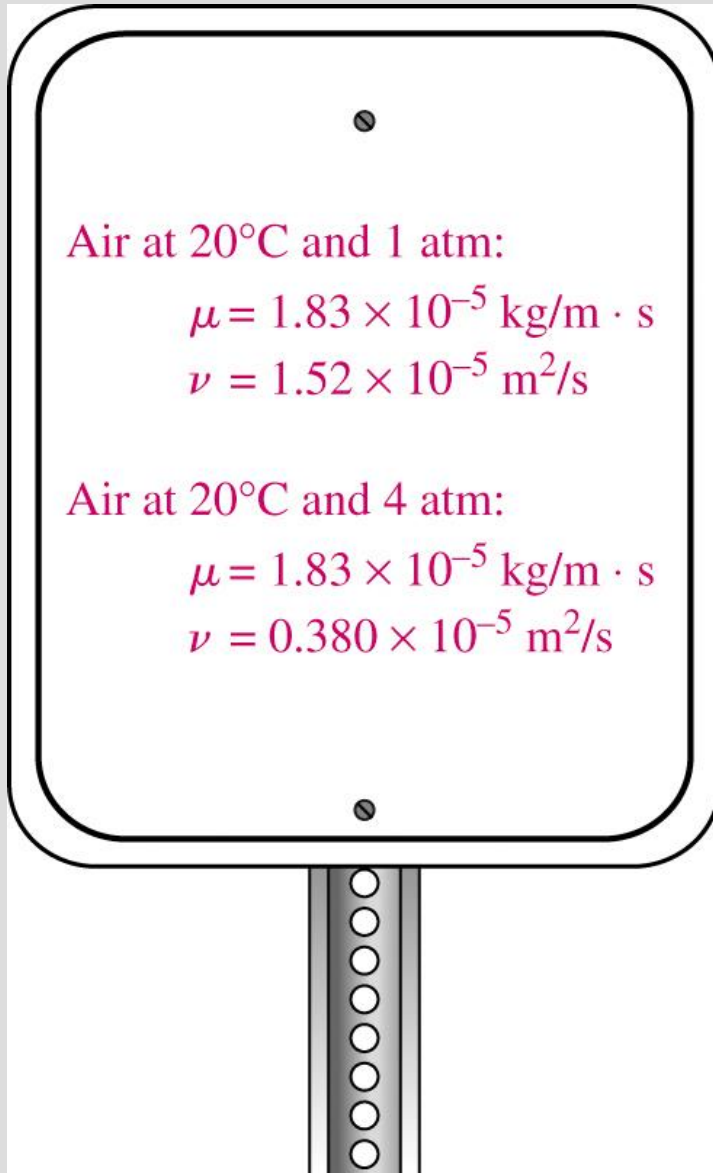

# Viscosity

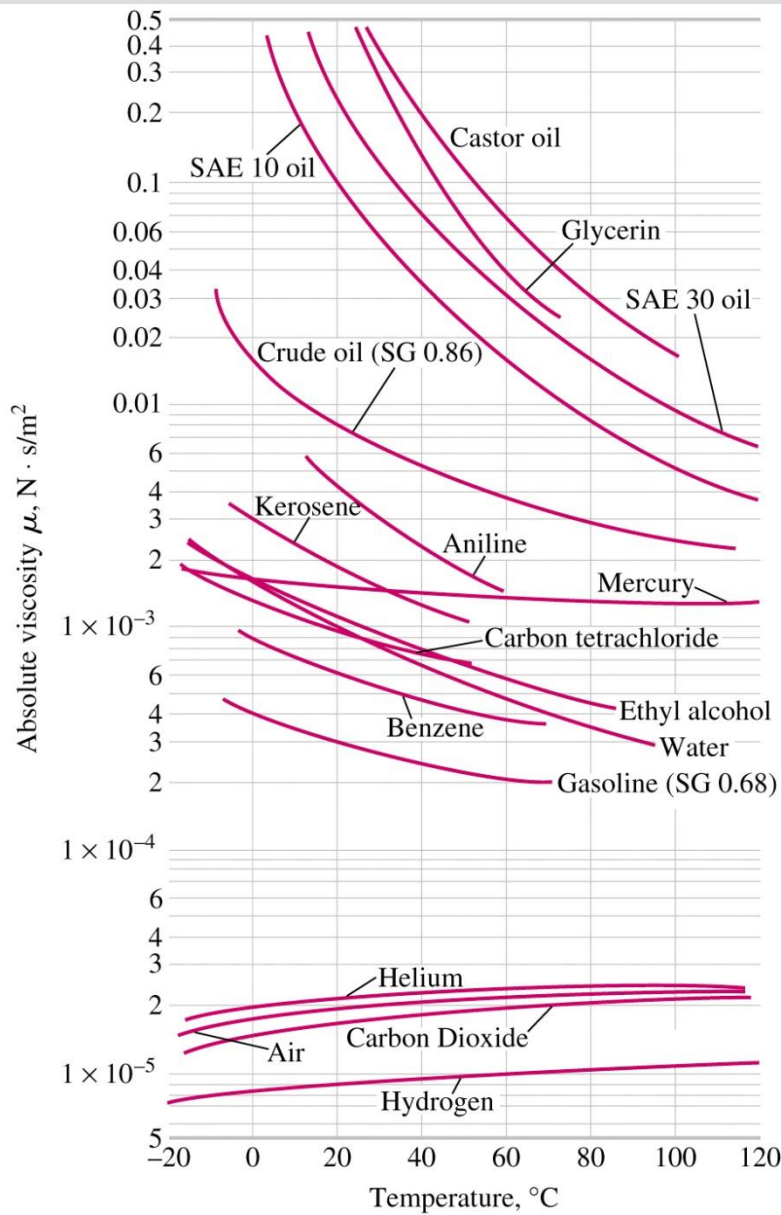

Dynamic viscosities of some fluids at 1 atm and 20°C (unless otherwise stated)

Fluid	Dynamic Viscosity $\mu$ , kg/m · s
Glycerin:	
-20°C	134.0
0°C	10.5
20°C	1.52
40°C	0.31
Engine oil:	
SAE 10W	0.10
SAE 10W30	0.17
SAE 30	0.29
SAE 50	0.86
Mercury	0.0015
Ethyl alcohol	0.0012
Water:	
0°C	0.0018
20°C	0.0010
100°C (liquid)	0.00028
100°C (vapor)	0.000012
Blood, 37°C	0.00040
Gasoline	0.00029
Ammonia	0.00015
Air	0.000018
Hydrogen, 0°C	0.0000088

# Example:

A 50-cm  $\times$  30-cm  $\times$  20-cm block weighing 150 N is to be moved at a constant velocity of 0.8 m/s on an inclined surface with a friction coefficient of 0.27. (a) Determine the force  $F$  that needs to be applied in the horizontal direction. (b) If a 0.4-mm-thick oil film with a dynamic viscosity of 0.012 Pa  $\cdot$  s is applied between the block and inclined surface, determine the percent reduction in the required force.

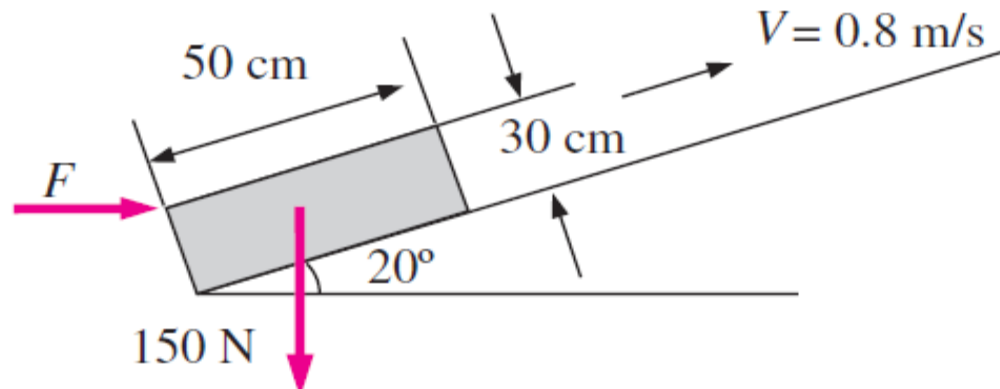

# Example:

A solid cone of angle  $2\theta$ , base  $r_0$ , and density  $\rho_c$  is rotating with initial angular velocity  $\omega_0$  inside a conical seat, as shown in Fig. P1.53. The clearance  $h$  is filled with oil of viscosity  $\mu$ . Neglecting air drag, derive an analytical expression for the cone's angular velocity  $\omega(t)$  if there is no applied torque.

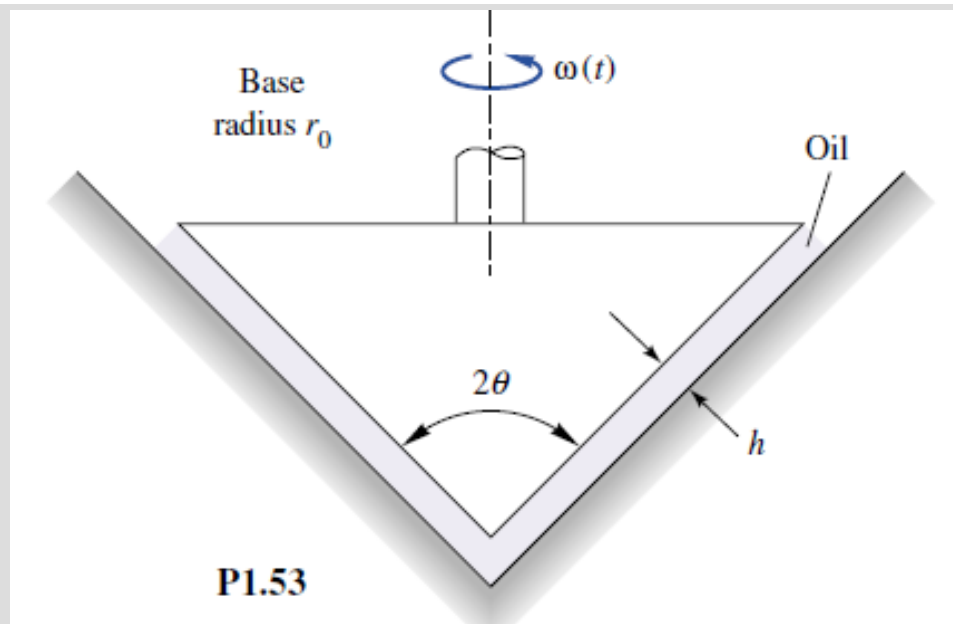

where  $I_o(\text{cone}) = \frac{3}{10} m r_0^2$ ,  $m = \text{cone mass}$