

Fast detection of rancidity in potato crisps using e-noses based on mass spectrometry or gas sensors

M. Vinaixa^a, A. Vergara^a, C. Duran^{a,b}, E. Llobet^{a,*}, C. Badia^a

^a Department Electronic Engineering, Universitat Rovira i Virgili, Avda. Països Catalans, 26, Campus Sescelades, 43007 Tarragona, Spain

^b Department Electronic Engineering, University of Pamplona, Km 1 Via Bucaramanga, Pamplona, Colombia

Available online 2 July 2004

Abstract

Well-established methods to assess rancidity in potato crisps such as the Rancimat or the acid degree value are time-consuming and labour-intensive. Here, we report on alternative methods, based on e-nose technology, to assess rancidity directly from potato crisps without any previous oil extraction step. This simplifies sample preparation, avoids the use of solvents or high temperatures and significantly speeds up the measurement process (from several hours down to 25 min). Two different e-noses were implemented. One was based on SPME coupled to fingerprint MS and the other one was based on dynamic headspace sampling and an array of metal oxide gas sensors. The two e-noses were used to classify crisps according to four stages of oxidative rancidity. While the MS e-nose reached a 100% success rate in this classification, the success rate of the GS e-nose was 68%. These results show that e-nose technology can be a useful tool for the crisp industry.

We show that it is possible to reliably assess rancidity in potato crisps by either a mass spectrometry or a gas sensor-based electronic nose. The two approaches are presented and their performance compared in the framework of this application.

© 2004 Elsevier B.V. All rights reserved.

Keywords: Metal oxide gas sensors; Mass spectrometry-based e-nose; Crisp rancidity

1. Introduction

Potato crisps are considered one of the most popular snack products in the world. Usually, they are made by deep-frying fresh potato slices in a vegetable oil bath. The reaction of lipid components with oxygen in the presence of light and heat is a major source of off-odours/flavours in food and, particularly, in potato crisps. During the deep-frying process, vegetable oil is under temperature stress and this can induce onset of rancidity as a consequence of oxidative reactions of lipids present in the oil. From the standpoint of food oxidation, the important lipids are the ones containing unsaturated fatty acids, particularly oleic acid (C18:1), linoleic acid (C18:2) and linoleic acid (C18:3) [1]. Potato crisps are fried in oils that contain a high amount of all of these. Unsaturation are reactive centres liable to be affected by oxidation. So, the greater the number of double bonds, the higher the probability that the fatty acid will react with oxygen to generate undesirable odours and flavours in

the product. The oxidation of lipids results in the formation of primary and secondary decomposition products, including hydroperoxides, carbonyls, alcohols, esters, carboxylic acids and hydrocarbons [2], which generally have unpleasant odour and may conduce to rancidity. Various factors can influence the occurrence of rancidity in crisps, such as storage conditions, presence of antioxidants, oil type, time of deep-frying, heat, presence of pro-oxidant metals, oxygen and moisture among other factors.

Two very important aspects for potato crisps producers are the detection of rancidity and its associated off-odours/flavours and the estimation of shelf-life. There are basically two reasons why it is important to monitor to what extent oil has undergone oxidation:

- Previous knowledge, i.e. an estimate, on the useful life of frying oil contributes to reduce the cost of the deep-frying process. There is an obvious economic advantage when crisp producers can appropriately determine the useful life of frying oils. Premature discarding of oils results in economic loss and, on the other hand, overuse of frying oil greatly affects the quality of fried products and causes undesirable nutritional effects [3].

* Corresponding author. Tel.: +34 977 558502; fax: +34 977 559605.
E-mail address: ellobet@etse.urv.es (E. Llobet).

- The second reason is an ever increasing consumer about quality and safety of food products. According to Marsili [4], the food industry needs the development of equipment and techniques to trace the quality of raw materials and finished products, not only in the production plant, but also during storage and vending. Monitoring of off-odours/flavours during the different processing steps should be conducted to ensure that the processes are being operated correctly. Finished products should be monitored too, ensuring that no off-flavours have developed. All these improvements would greatly contribute to food quality and consumer satisfaction.

Nowadays, there are some 360 procedures to verify the quality of oil either during the process of frying or in finished products [1,5]. However, there is not a reliable, easy-to-use and fast method to determine rancidity in potato crisps. The most well-established methods for the evaluation of rancidity are based on sensory evaluation or chemical analysis. Some of these methods are revised below:

- Sensory analysis: Samples are evaluated by a panel of experts. This is a slow and expensive method. It requires the panel to be integrated by highly trained personnel and, however, results can be somewhat subjective.
- Peroxide value (PV): This method determines all the substances, in terms of milliequivalents of peroxide per gram of sample, which oxidise potassium iodine under the conditions of the test. These substances are generally assumed to be peroxides or other similar products of fat oxidation. The higher the PV, the more oxidised the fat is and the higher the likelihood of off-odours/flavours.
- Acid degree value (ADV): This is a titration method. It obtains the amount of potassium hydroxide required to neutralise the free fatty acids hydrolysed with 95% ethanol. The higher the ADV, the higher the level of free fatty acids present in the oil. Free fatty acids indicate undesirable hydrolysis, which results in flavour deterioration. Che Man et al. [3] showed that ADV was an important indicator of frying oil quality, and highly correlated with the shelf-life of potato chips.
- Iodine value (IV): Indicates the number of double bonds or degree of unsaturation in lipids. It can be used as an estimate of the oxidation stability of a lipid.
- HPLC analysis: Determination of the fatty acid composition of oil. This method provides fatty acid profiles and is more informative than IV.
- IR and UV band absorption of some oxidation by-products like hexanal, pentanal and pentane.
- Methods based on the measurement of some physical properties of oil, such as melting point, solid fat index and refractive index.
- Rancimat test: Measures the susceptibility of oil to oxidation. An oil sample is kept at 120 °C in a vessel where air flows to extract volatiles from the headspace. These volatiles are then collected in water. The conductivity of water is monitored and results expressed as Rancimat

hours indicate the time at which oxidative rancidity occurs. Rancidity triggers a sharp increase in water conductivity. Since this test is very informative about the resilience to rancidity of oils, it has become a reference in the crisp industry.

All the methods cited above can be used to assess rancidity in potato crisps, provided that a process to extract oil from the crisps is performed. Oil extraction is a very time-consuming, complex and labour-intensive step for routine quality control applications. Furthermore, the solvents or the methods used can induce oxidation and distort final results. Since the crisp industry demands a large number of samples to be analysed and high sample throughput, there is a need for faster and simpler methods to assess crisp rancidity and off-odours/flavours. In this context, the use of e-nose technologies would be of help.

In the last decade, the use of e-nose technology in many food-related applications has been studied. Electronic noses are multisensor instruments that use a suitable pattern recognition engine to classify complex odour patterns. According to previous works, electronic noses based on metal oxide gas sensors are suitable for the discrimination of different stages of lipid oxidation in oils [6–8]. In the last few years, mass spectrometry-based e-noses (MS e-noses) are becoming an increasingly used alternative (or complement) to gas sensor-based e-noses in food quality applications [4,9]. The use of pre-concentration and extraction techniques such as solid-phase micro-extraction (SPME) have improved the sensitivity and reproducibility of MS e-noses [4,10].

In this work, we report, for the first time, on the design and use of two e-noses to assess rancidity directly from potato crisps, without any previous oil extraction step. This greatly simplifies sample preparation, avoids unwanted artefacts derived from oil extraction and speeds up the measurement process. The two e-noses are based on SPME–MS and an array of semiconductor gas sensors (GS e-nose), respectively. In the next section, details on the e-nose architectures sample preparation and measurements run are given. In Section 3, the results are shown and the usefulness of the methods implemented for the application considered is discussed.

2. Experimental

2.1. Experiment 1

2.1.1. Crisp samples

Four boxes (labelled A–D) with 200 g packs (12 packs per category) of potato crisps were prepared by Frit Ravich, S.L. These crisps belonged to the same frying batch of 50% palm and 50% sunflower oil, but they underwent different rancidity accelerating treatments:

- Crisps in box A were stored during 28 days in a dry and dark conservation chamber, where their temperature was kept around 20 °C.

- Crisps B–D were kept during 14, 21 and 28 days, respectively, in a rancidity accelerating chamber. The chamber was kept at high temperature (around 40 °C) and UV light was used to promote oxidation. As soon as the samples within a given category finished their ageing treatment, they were removed from the rancidity chamber and stored in the conservation chamber to maintain unchanged the rancidity stage reached.

2.1.2. Measurement procedures

The content of each potato pack was split to perform consistent measurements with an MS e-nose and a GS e-nose.

2.1.2.1. Metal oxide sensors-based electronic nose. The electronic nose system was designed to measure volatiles directly from the packs of the crisps. The system consisted of a sensor chamber where seven TGS-type sensors and five FIS sensors were housed, several electrovalves, tubing and a pump (see Fig. 1a). A similar set-up is described elsewhere [11]. The measurement procedure consisted of two steps. In the first step, (measurement phase) the electrovalves

were set to form a closed loop between the sensor chamber and the pack containing the crisps under analysis. The air flow (150 ml/min) was re-circulated, which caused a dynamic sampling of the crisps' headspace. During this phase, which lasted 10 min, the resistance of the sensors was acquired and stored for later processing. Finally, in the second step (cleaning phase), the crisp pack was removed and the system was cleaned with dry air during 20 min before a new measurement could start.

After a pack of crisps had been measured by the GS e-nose, 4 ± 0.2 g of the crisps were crushed and put into a 20 ml vial that was immediately capped and sealed with a Teflon septum. A subsequent analysis with the MS e-nose system was run.

2.1.2.2. Mass spectrometry-based electronic nose. A Shimadzu QP 5000 gas chromatograph–mass spectrometer was used to implement an MS e-nose. The separation column was replaced by a 5 m deactivated fused silica column to co-elute all volatile components achieving one single peak for all the components in the headspace of crisps. The column

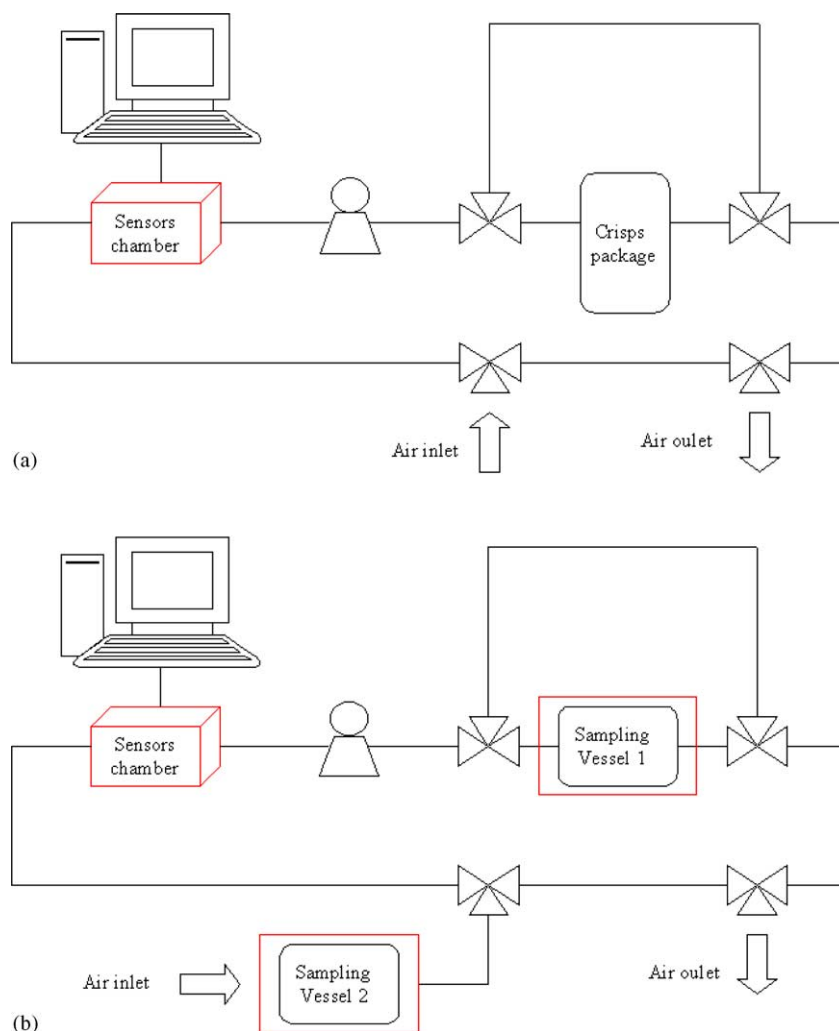

Fig. 1. Block diagram of the gas sensor-based e-nose used in experiment 1 (a) and experiment 2 (b).

was kept isothermal at 250 °C and the helium flow was set to 1.4 ml/min. This implies that the components in the headspace of crisps were directly analysed without chromatographic separation. For a given measurement, the resulting mass spectrum gives a fingerprint that is characteristic of the volatiles present in the headspace of the sample.

The vials that contained the samples to be measured were placed inside a thermostatic bath (50 °C) to promote the presence of volatiles in the headspace. SPME was performed by introducing a 75- μ m Carboxen/PDMS fibre into the vial and exposing it to the headspace of crisps for 20 min. Thermal desorption of the volatiles trapped on the fibre was conducted for 3 min in the chromatograph injection port at 300 °C. It was equipped with a 0.75-mm i.d. liner to optimise SPME desorption and sample delivery onto the column. The split valve was closed during desorption. The quadrupole mass spectrometer acquired in scan mode, and the mass range used was m/z 35 to m/z 390 at 0.5 scan/s. To ensure the complete cleaning of the fibre, it was left five additional minutes in the injector port.

2.1.2.3. Rancimat, ADV and chromatographic profiles. Rancimat and ADV tests were performed at the quality laboratory of Frit Ravich, S.L. The chromatographic profiles were obtained at the Gas Sensor Lab of the University Rovira i Virgili, using a Shimadzu QP 5000 GC/MS. After sample preparation (as described above), the SPME fibre was introduced into the GC injection port and thermally desorbed for 5 min at 250 °C onto an Equity-5 poly (5% diphenyl/95% dimethylsiloxane) (30 m \times 0.25 mm \times 0.25 μ m) capillary column, purchased from Supelco Inc. The injector port was also equipped with a 0.75-mm i.d. liner. The GC oven was held at 45 °C during 1.5 min. Then, its temperature was raised up to 250 °C at 6 °C/min rate. Helium at 1.2 ml/min was used as carrier gas. Mass detector was operating in the electron impact ionisation mode (70 eV) with a scan range of 35 to 290 amu. The ion source temperature was kept at 250 °C.

2.2. Experiment 2

A new experiment was performed with an improved version of the gas sensor-based electronic nose. The main differences with the previous system were the use of a 12-element TGS-type sensor array (the seven TGS sensors already used in the first experiment + five TGS sensors added) and a new sample delivery method.

2.2.1. Crisp samples

Four boxes (labelled A–D) with 200 g packs of crisps (12 packs per category) were prepared by Frit Ravich S.L. in a similar way to the crisps used in experiment 1.

- Crisps in box A were stored during 18 days in the same conservation chamber used in experiment 1.

- Crisps B–D were kept during 6, 12 and 18 days, respectively, in the rancidity accelerating chamber used in experiment 1.

2.2.2. Improved gas sensor-based e-nose

The sample delivery system consisted of two temperature-controlled stainless-steel vessels (see Fig. 1b): a sampling vessel and a reference vessel. These chambers were identical and kept heated at 70 °C. To run a measurement, crisp samples (60 \pm 1 g) were placed into an aluminium tray and inserted into the sampling vessel. An identical (but empty) aluminium tray was also placed inside the reference vessel. New aluminium trays were used at each new measurement to avoid cross-contamination between samples. The measurement procedure was as follows:

In the first step (concentration phase), the crisps were heated at 70 °C for 30 min inside the sampling vessel, which was kept closed by the electrovalves. This allowed the volatiles from the crisps to concentrate in the headspace. During this phase, clean air flowed at 150 ml/min through the sensor chamber via the reference vessel.

In the second step (measurement phase), the electrovalves were set to form a closed loop between the sensor chamber and the sampling vessel. The air flow (150 ml/min) was re-circulated, which caused a dynamic sampling of the crisps' headspace. During this phase, which lasted 10 min, the resistance of the sensors was acquired and stored for later processing. The use of identical sampling and reference vessels is essential to ensure that sensor responses are solely due to the volatiles in the headspace of the crisps.

Finally, in the third step (cleaning phase) the crisps were removed from the sampling vessel and the system was cleaned with dry air during 20 min, before the concentration phase of a new measurement could start.

3. Results and discussion

3.1. Experiment 1

3.1.1. Rancimat, ADV and chromatographic profiles

Fig. 2(a) shows the Rancimat and ADV results for crisp samples A–D in experiment 1. The monotonous decrease in Rancimat time combined with an increase in the ADV for samples A–D shows that these categories correspond to crisps with increasing oxidative rancidity. Furthermore, the clear differences in Rancimat time between categories suggest that crisps in different categories are in significantly different rancidity stages. While there is an important difference in Rancimat time between samples A and B, they share an almost identical ADV. This suggests that ADV may not be suitable to assess the early stages of rancidity in crisps.

Chromatographic profiles of the headspace of crisps belonging to class A (fresh) and class D (rancid) were

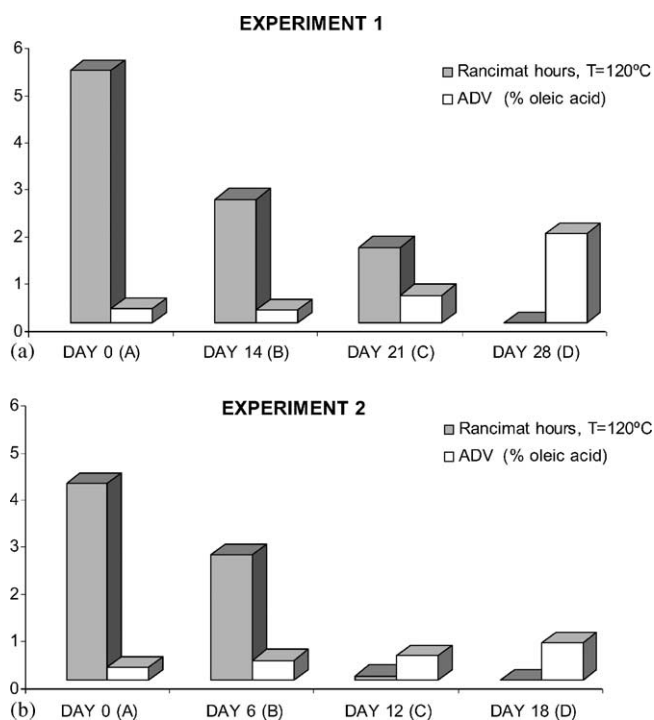

Fig. 2. Results of the Rancimat and ADV tests for potato crisps in experiment 1 (a) and experiment 2 (b).

measured. These profiles are shown in Fig. 3. Different volatile molecules appear or substantially increase their signal intensity as rancidity develops. These include acetone (peak no. 1), acetic acid (2), pentanal (3), hexanal (5), heptanal (6), hexanoic acid (9), 3-octen-2-one (10), 2-octenal (11), 2,3-octanedione (12), 2,4-decadienal (14) and undecane (15). Some of these components, such as acetic acid, pentanal, hexanal, heptanal and hexanoic acid, have been reported to be present in the chromatographic profiles of rancid chips [12]. 2,4-decadienal [14], which is present in a similar intensity in fresh and rancid crisps, has been identified by GC-olfactometry [13,14] as a predominant note in deep-fried potato crisps.

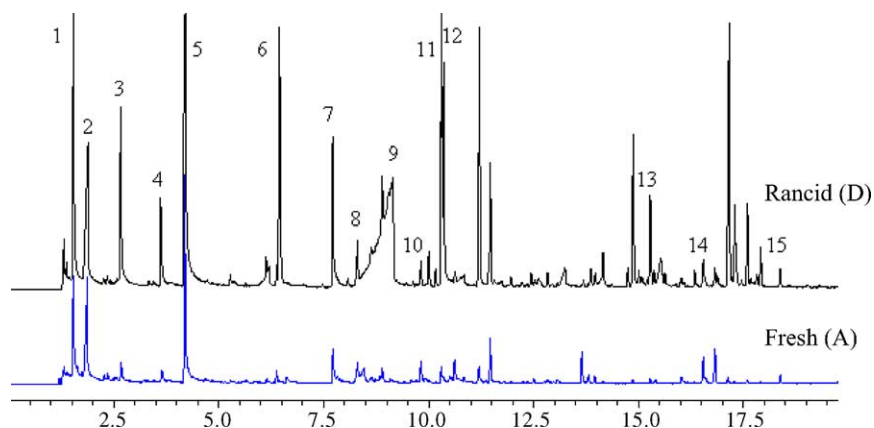

Fig. 3. Chromatographic profiles identified by GC/MS (1) acetone, (2) acetic acid, (3) pentanal, (4) pentanol, (5) hexanal, (6) heptanal, (7) 2-heptenal, (8) 1-octen-3-ol, (9) hexanoic acid, (10) 3-octen-2-one, (11) 2-octenal, (12) 2,3-octanedione, (13) 2-decenal, (14) 2,4-decadienal, (15) undecane.

3.1.2. Mass spectrometry-based e-nose

Nine replicate measurements per sample category were performed. For each measurement, a response spectrum was obtained by averaging mass spectra along the detected peak. The variables selected were from m/z 35 to m/z 120. The components identified as indicators of rancidity in the chromatographic profiles have base peaks that lie in the range selected. Therefore, the data matrix, \mathbf{R} , consisted of 86 columns (variables) and 36 rows (measurements). A linear discriminant analysis (LDA) was performed on \mathbf{R} . This is a supervised method (e.g. the classes to be discriminated are known before this analysis is performed). Geometrically, the rows of the response matrix, \mathbf{R} , can be considered as points in a multidimensional space. Discriminating axes are determined in this space in such a way that optimal separation of the predefined classes is attained. Like PCA, LDA finds new orthogonal axes (factors) as a linear combination of the input variables. Unlike PCA, however, LDA computes the factors as to minimise the variance within each class and maximise the variance between classes. The first factor will be the most powerful differentiating dimension, but later factors may also represent additional significant dimensions of differentiation.

The data matrix was mean-centred before the LDA was performed. If this scaling of the data is not performed, there is a risk of LDA ignoring mass intensities with low mean (but important for discriminating the four rancidity classes) in front of mass intensities with high mean. The two first factors accounted for more than 99% of the variance in the data. LDA results are shown in Fig. 4. Replicate samples of a given category cluster together with low dispersion, which shows the good repeatability of the MS e-nose. Fig. 4 shows that crisp samples with increasing rancidity appear ordered from left to right along the first factor. While samples from categories A (fresher) and D (more rancid) appear in clusters well apart, the clusters of categories B and C are very near. These results are in very good agreement with the Rancimat tests (see Fig. 1a). For example, while there is a moderate change in the Rancimat time between samples in categories

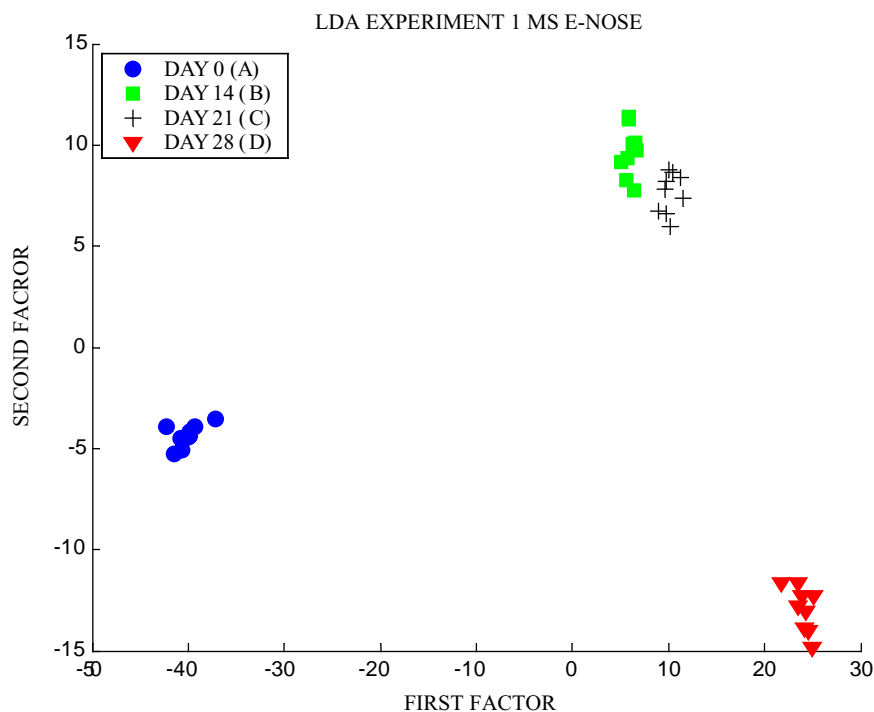

Fig. 4. Results of a linear discriminant analysis for the measurements gathered with the mass spectrometry-based e-nose in experiment 1.

B and *C*, there is a dramatic change in this parameter between samples in categories *A* and *B* and also between samples in *C* and *D*. Therefore, MS e-nose results are in excellent agreement with Rancimat results.

A fuzzy ARTMAP neural network was used to classify the samples within the four categories of rancidity (*A–D*). Because of the limited number of measurements available (36), the network was tested using the leave-one-out cross-validation method. Given n measurements, the network was trained n times using $n - 1$ training vectors. The vector left out during the training phase (i.e. unseen by the network) was then used for testing. Performance was estimated as the averaged performance over the n tests. For each iteration of the cross-validation process, a different row from the data was left out. The remaining 35 rows conformed the restricted data matrix. A pre-processing step was performed on the restricted data matrix, which consisted of computing a 4-class LDA and retaining the two first factors. The scores of the 35 measurements conformed the new data matrix. Therefore, this new matrix had 35 rows and 2 columns. The matrix was then normalised because the fuzzy ARTMAP network needs that its input data lie in the range [0, 1]. Once the data matrix had been pre-processed, it was used to train the neural network model. After the training phase, the network was validated using the vector that had been left out (i.e. validation vector). The procedure was as follows:

Because a LDA had been used as pre-processing, then the scores of the validation vector were calculated by projecting its components onto the space of factors. In the second step,

the validation vector was normalised. Finally, the validation vector was input into the neural network model, which produced a classification result. The fact that the validation vector had been left out before any pre-processing of the data ensured that this vector was completely 'new' for the neural network.

The number of inputs to the network was set to 2 (the scores on the two first factors). The number of outputs was set to 4 because a 1-of-4 code was used for the different classes (*A*: 0001, *B*: 0010, *C*: 0100 and *D*: 1000). For example, the activation of the first output neurone (i.e. output pattern 0001), implies that an input vector is recognised as belonging to class *A* (fresh crisps). This approach aimed at identifying rancidity in a semi-quantitative way. The baseline vigilance parameter was set to 0. This is the recommended value for the vigilance since it allows for very coarse categories and the match tracking system will only refine these categories if necessary. The re-code rate was set to 0.5. This value allows the established categories to be modified if there is a persistent attempt to do so (slow recode). The value of the choice parameter was set to 0.1. The Fuzzy ARTMAP network could learn the training set in just one iteration. The number of committed nodes, which play a similar role as hidden neurones in multilayer perceptron networks, ranged between 4 and 6 after the network had been trained. Under these conditions, the success rate reached in rancidity classification was 100%. This shows that the SPME-MS e-nose was able to assess crisp rancidity from the volatiles present in the headspace of the crisps.

3.1.3. Gas sensor-based e-nose

The responses of the 12 metal oxide gas sensors to the different crisp samples were obtained. The feature extracted from each sensor response was the conductance change, defined as $\Delta G = G_{\max} - G_o$, where G_{\max} is the maximum value of the sensor electrical conductance in the presence of the volatiles from the headspace of the crisps, and G_o is the sensor conductance in the presence of air (i.e. the baseline conductance). The responses of the FIS sensors were very weak compared with the responses of the TGS sensors. Therefore, only the responses of the seven TGS sensors were used for further analysis. A LDA was performed on the mean-centred response matrix. The two first discriminant factors accounted for more than 99% of variance in the data. LDA results are shown in Fig. 5. While measurements that correspond to fresh crisps (class A) cluster together, the clusters of measurements corresponding to the remaining three classes appear clearly overlapped along the first and second discriminant factors. A fuzzy ARTMAP was used to classify the samples according to their rancidity stage. The same training and validation techniques employed with the MS e-nose were implemented. The neural network had seven inputs (seven TGS sensors) and four outputs. The number of committed nodes during the repeated training and validation processes varied between 8 and 12. Under these conditions, the success rate reached in rancidity classification was 56%. The samples misclassified belonged to categories B–D.

According to these results, the GS e-nose showed lower repeatability and discriminating power than the MS e-nose. However, an important difference between the two e-nose

methods lies in sample preparation. While for the GS e-nose volatiles were sampled from the headspace of the crisps at room temperature, the MS e-nose made use of a SPME from the headspace of crisps heated at 50 °C. Therefore, the differences in classification success rate between the two e-noses could be due to significant differences in the headspaces sampled. This is why a new experiment was designed.

3.2. Experiment 2

3.2.1. Rancimat and ADV results

Fig. 2b shows the Rancimat and ADV results for crisp samples A–D in experiment 2. The oil used to deep-fry the crisps in experiment 2 had the same composition than the one used in the previous experiment. However its initial stage (class A) was, according to the Rancimat test, more evolved towards rancidity. The results of the Rancimat test showed that the classification of samples in four rancidity categories was going to be more challenging here, because samples in classes C and D had very similar Rancimat and ADV results.

3.2.2. Gas sensor-based e-nose

The GS e-nose with a re-designed sample delivery system was used. The responses of the 12 TGS-type metal oxide gas sensors to the different crisp samples in experiment 2 were obtained. The feature extracted from each sensor response was, once again, the conductance change. Since 12 replicate measurements per category were gathered, the response matrix had 48 rows and 12 columns. A LDA was performed on the mean-centred data matrix. The two first

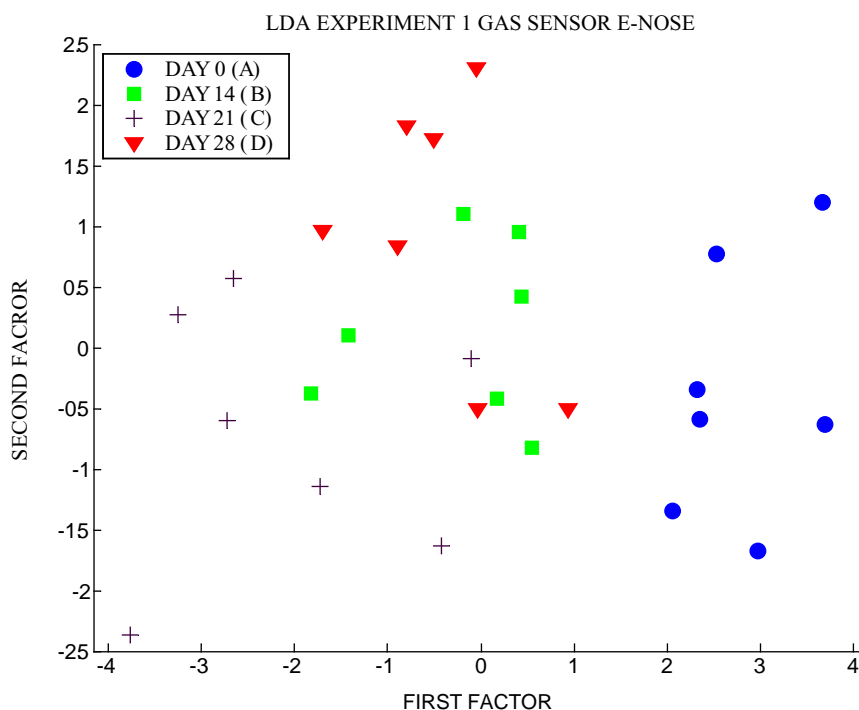

Fig. 5. Results of a linear discriminant analysis for the measurements gathered with the gas sensor-based e-nose in experiment 1.

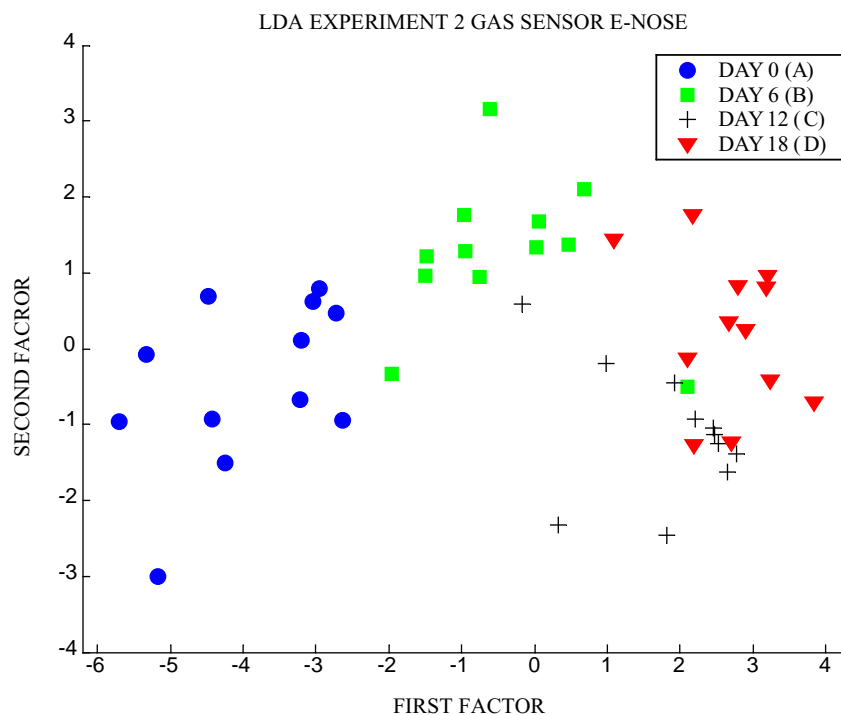

Fig. 6. Results of a linear discriminant analysis for the measurements gathered with the gas sensor-based e-nose in experiment 2.

factors accounted for more than 99% of variance in the data. LDA results are shown in Fig. 6. This figure shows that crisp samples with increasing rancidity appear ordered (with some overlapping) from left to right along the first factor. Overlapping occurs between samples in categories C and D, which is in good agreement with the very similar Rancimat times found for these categories. These results suggest that it is necessary to heat the crisps for a headspace that is representative of their rancidity stage to develop.

A fuzzy ARTMAP was, once again, used to classify the samples according to their rancidity stage. The same training and validation techniques employed in experiment 1 were implemented. The neural network had 12 inputs (12 TGS sensors) and 4 outputs. The number of committed nodes during the repeated training and validation processes varied between 7 and 10. Under these conditions, the success rate reached in rancidity classification was 68%. Considering that the classification problem envisaged in experiment

2 was more challenging, a 68% rate of successful classifications compares very favourably with the 56% success rate reached in experiment 1. Table 1 shows the confusion matrix for experiment 2. It can be seen that most confusions occur between consecutive rancidity categories (only two samples belonging to class D were misclassified as belonging to class B).

These promising results show that the GS e-nose with improved sample delivery system is able to perform a semi-quantitative classification of crisp rancidity.

4. Conclusions

In this work, we have reported on the design and use of two e-noses to assess rancidity directly from potato crisps, without any previous oil extraction step. This simplifies sample preparation, avoids the use of solvents to extract oil and speeds up the measurement process. The two e-noses were based on fingerprint mass spectrometry and an array of metal oxide gas sensors, respectively. While a single measurement using either the Rancimat or the ADV test takes typically some hours to complete, a measurement with the MS e-nose or the GS e-nose takes 25 and 40 min, respectively.

Sample conditioning plays a very important role. A mild heating of the crisps (up to 70 °C) is necessary for a headspace that is representative of their rancidity stage to develop. Under these conditions, the MS e-nose and the GS e-nose have been found sensitive enough and suitable for semi-quantitatively assessing rancidity in potato crisps. The results obtained by both e-nose instruments are in very good

Table 1

Confusion matrix for the classification of crisps samples in four categories of rancidity (A–D) in experiment 2, using a fuzzy ARTMAP neural network

	Actual			
	A	B	C	D
Predicted as				
A	9	2	0	0
B	3	8	2	2
C	0	2	8	2
D	0	0	2	8

agreement with the Rancimat test. Therefore, the assessment of crisp rancidity using e-nose technology could become a routine test in the quality laboratories of crisp producers.

Further work is in progress to analyse the shelf-life of potato crisps.

Acknowledgements

The authors gratefully acknowledge financial support from the Spanish Institute of Agro-Food Technology, INIA, under Project no. CAL01-052-C2.

References

- [1] R. Marsili, Controlling the Quality of Fats and Oils, 1993. <http://www.foodproductdesign.com>.
- [2] N. Shen, S. Duvick, P. White, L. Pollack, Oxidative stability and AromaScan analyses of corn oils with altered fatty acid content, *J. Am. Oil Chem. Soc.* 76 (12) (1999) 1425–1429.
- [3] Y.B. Che Man, J.L. Liu, R.A. Rahman, B. Jamilah, Shelf-life of fried potato chips using palm olein, soybean oil and their blends, *J. Food Lipids* 6 (1999) 287–298.
- [4] R. Marsili, Flavor, Fragrance and Odor Analysis, Marcel Dekker, Inc., New York, 2002.
- [5] AOCS, Official Methods and Recommended Practices of the American Oil Chemists' Society, fifth ed., 1998.
- [6] M. Adechy, V.P. Shiers, J.B. Rossell, Study of rancidity and resistance to oxidation in edible oils and fats using electronic nose technology in comparison with conventional analytical techniques, *Leatherhead Food R.A. Research Reports*, no. 751, 1998.
- [7] Y.M. Yang, K.Y. Han, B.S. Noh, Analysis of lipid oxidation of soybean oil using the portable electronic nose, *Food Sci. Biotechnol.* 9 (3) (2000) 146–150.
- [8] M. Muhl, H.U. Demisch, F. Becker, C.D. Kohl, Electronic nose for detecting the deterioration of frying fat – comparative studies for a new quick test, *Eur. J. Lipid Sci. Technol.* 102 (2000) 581–585.
- [9] R.T. Marsili, SPME–MS–MVA as an electronic nose for the study of off-flavors in milk, *J. Agree. Food Chem.* 47 (1999) 648–654.
- [10] E. Schaller, S. Zenhäusern, T. Zesiger, J.O. Bosset, F. Escher, Use of preconcentration techniques applied to a MS-based “Electronic Nose”, *Analisis* 28 (2000) 743–749.
- [11] J. Brezmes, E. Llobet, X. Vilanova, J. Orts, G. Saiz, X. Correig, Correlation between electronic nose signals and fruit quality indicators on shelf-life measurements with pinklady apples, *Sens. Actuators B* 80 (2001) 41–50.
- [12] R.E. Shirey, L.M. Sidisky, Analysis of Flavors and Off-Flavors in Foods and Beverages Using SPME, Supelco Application Note, <http://www.infonew.sigma-aldrich.com/Graphics/Supelco/objects/8600/8564.pdf>.
- [13] R.K. Wagner, W. Grosch, Key odorants of french fries, *J. Am. Oil Chem. Soc.* 75 (10) (1998) 1385–1392.
- [14] R.K. Wagner, W. Grosch, Evaluation of potent odorants of french fries, *Food Sci. Technol.* 30 (2) (1997) 164–169.